



Vantage VUE[®]

Console Manual

Model #6351

FCC Part 15 Class B Registration Warning

This equipment has been tested and found to comply with the limits for a Class B digital device, pursuant to Part 15 of the FCC Rules. These limits are designed to provide reasonable protection against harmful interference in a residential installation. This equipment generates, uses, and can radiate radio frequency energy and, if not installed and used in accordance with the instructions, may cause harmful interference to radio communications.

However, there is no guarantee that interference will not occur in a particular installation. If this equipment does cause harmful interference to radio or television reception, which can be determined by turning the equipment on and off, the user is encouraged to try to correct the interference by one or more of the following measures:

- Reorient or relocate the receiving antenna.
- Increase the separation between the equipment and receiver.
- Connect the equipment into an outlet on a circuit different from that to which the receiver is connected.
- Consult the dealer or an experienced radio/TV technician for help.

Changes or modification not expressly approved in writing by Davis Instruments may void the warranty and void the user's authority to operate this equipment.

FCC ID: IR2DWW6351

IC: 3788A-6351

EC EMC Compliance

This product complies with the essential protection requirements of the EC EMC Directive 2004/108/EC; Low Voltage Directive 2006/95/EC; and Eco-Design Directive 2005/32/EC >0.5 watt no-load adaptor.
RoHS Compliant

Vantage Vue Console Manual

Document Part Number: 07395.261

Rev. G, September 4, 2014

For Vantage Vue Consoles #6351

And Vantage Vue Weather Stations #6250, 6357

Vantage Vue® and Vantage Pro2™ are trademarks of Davis Instruments Corp., Hayward, CA.

© Davis Instruments Corp. 2014. All rights reserved. Davis Instruments Quality Management System is ISO 9001 certified.

Information in this document subject to change without notice.



3465 Diablo Avenue, Hayward, CA 94545-2778 U.S.A.

510-732-9229 • Fax: 510-732-9188

E-mail: info@davisnet.com • www.davisnet.com

Table of Contents

Welcome to Vantage Vue	1
Console Features: Keyboard & Display	1
In This Manual	2
Vantage Vue System Installation Steps	2
Installing the Console	3
Powering the Console	3
Installing Batteries	3
Installing the AC Power Adapter (Optional)	4
Console Location	4
Table & Shelf Placement	5
Wall Mounting	5
Using Your Weather Station	6
Console Modes	6
Setup Mode	6
Setup Mode Commands	6
Screen 1: Time & Date	7
Screen 2: Time Zone	7
Screen 3: Daylight Saving Settings	8
Screen 4: Daylight Saving Status	8
Screen 5: Active Transmitters	8
Screen 6: Configuring Transmitter IDs	9
Screen 7: Retransmit	10
Screens 8 and 9: Latitude and Longitude	10
Screen 10: Elevation	11
Screen 11: Barometric Reduction Setting	11
Screen 12: Wind Cup Type (Optional)	12
Screen 13: Rain Collector	12
Screen 14: Rain Season	13
Screens 15 and 16: Cooling and Heating Degree Day Base	13
Screens 17 and 18: Commentary and Key Beep	14
Screen 19: Baud Rate (Optional)	14
Exiting Setup Mode	15
Clear All Command	15
Current Weather Mode	15
Current Weather Mode Commands	16
Displaying Weather Variables	16
Time & Date, Sunrise & Sunset Time, Moon Phase, Forecast Icons	17
Wind Speed and Direction	17
Inside and Outside Temperature	18
Humidity	20
Barometric Pressure	20
Pressure Trend	22
Wind Chill	22

Dew Point	22
Heat Index	23
Rain	23
Evapotranspiration (ET) (Optional)	25
Weather Center	25
Light	26
Selecting Units of Measure	26
Calibrating, Setting, and Clearing Variables	27
Calibrating Temperature and Humidity	27
Calibrating Wind Direction Reading	27
Calibrating Barometric Pressure	28
Calibrating Rain	28
Setting Weather Variables	28
Clearing Weather Variables Accumulations & Calibrations	29
Clear All Command	29
Highs and Lows Mode	30
Viewing Highs and Lows	30
Alarm Mode	31
Special Alarms	32
Setting Alarms	32
Setting the Time Alarm.....	33
Clearing Alarm Settings.....	33
Silencing Alarms	33
Changing Alarm Sound.....	33
Graph Mode	33
Viewing Graphs	34
Troubleshooting and Maintenance	36
Vantage Vue Troubleshooting Guide	36
Troubleshooting Reception Problems.....	37
Check Console Reception	38
Console Diagnostic Mode	38
Diagnostic Screen Commands	38
Screen 1: Statistical Diagnostic Screen	39
Screen 2: Reception Diagnostic Screen	40
Console Maintenance	41
Changing Batteries	41
Console Firmware Versions	41
One Year Limited Warranty	41
Contacting Davis Technical Support	41
Appendix A: Weather Data	42
Appendix B: Specifications	47
Appendix C: Wireless Repeater Configuration	51

Chapter 1

Welcome to Vantage Vue

The console of your new Vantage Vue wireless weather station displays and records your station's weather data, provides graph and alarm functions, and interfaces to a computer using our optional WeatherLink[®] software.

Your Vantage Vue station also includes an outdoor Integrated Sensor Suite (ISS) that transmits outside sensor data to the console via a low-power radio. The console displays all the information coming from the ISS in an easy-to-use format. It can also receive data from a Davis Vantage Pro2[™] weather station. The *Vantage Vue Quick Reference Guide* included with your station provides an easy-to-use reference for most console functions.

Console Features: Keyboard & Display

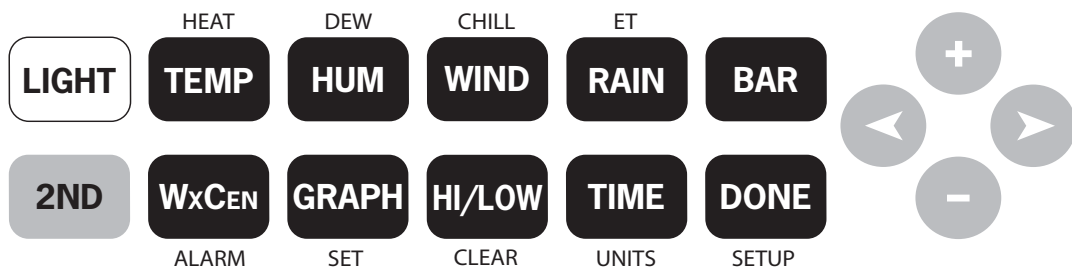

Vantage Vue Keyboard

Use the keyboard to access and scroll through current and historical data for individual variables, set and clear alarms, enter calibration values, set up and view graphs, and view detailed weather information available for each variable.

The keyboard consists of 12 command keys and four navigation keys. A weather variable or console command is printed on each command key. Just press a key to select the variable or function printed on that key.

Each command key also has a secondary function which is printed above the first row of keys or below the second row of keys. To select the secondary function, press and release 2ND and then immediately press the key for that function.

After pressing 2ND, the **2nd** icon displays above the moon phase icon on the screen indicating that all secondary key functions are enabled. Keys resume normal operation after the icon disappears (about 7-8 seconds).

The + and - navigation keys along with the < and > navigation keys are used to select command options, adjust values, and to provide additional functions when used in combination with a command key.

An arrow **▶** appears next to the variable selected in the display.

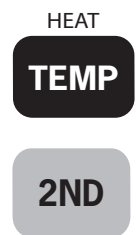

In Current Weather Mode, the display shows the time and date, the likely forecast within the next 12 hours, current moon phase, and weather information for up to 8 different weather variables at a time. It also displays additional information pertinent to a selected variable in the Weather Center in the bottom right section of the console screen.

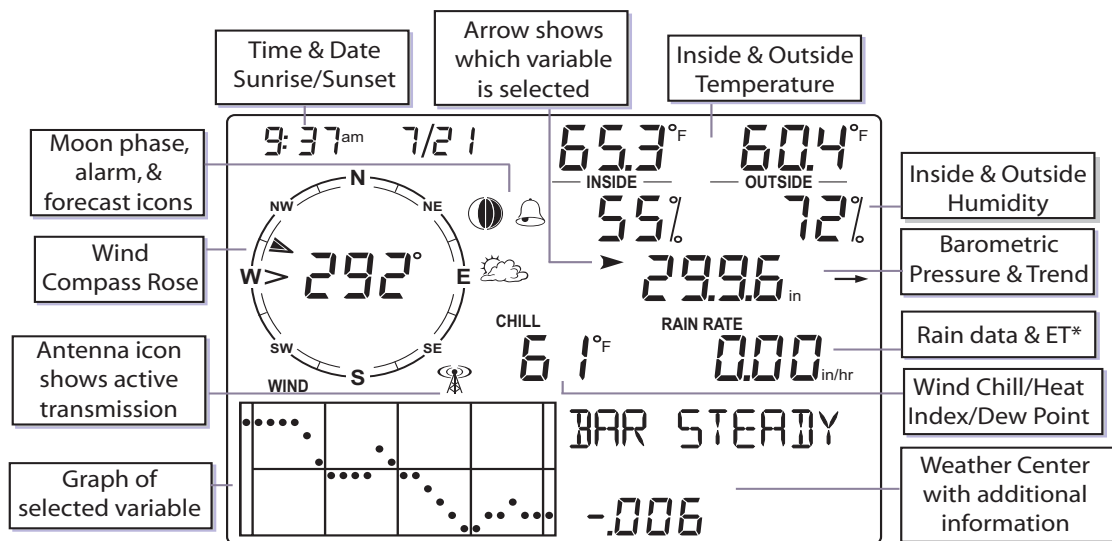

*ET, optional, available only when used with a Vantage Pro2 Plus or a Vantage Pro2 with Solar Radiation sensor.

In This Manual

This manual contains all the information you will need to power, set up, and use your console. It also includes a troubleshooting section for solving some basic console issues.

- See “Installing the Console” on page 3 for information on powering and placing or mounting your Vantage Vue console.
- See “Setup Mode” on page 6 for information on configuring and setting up your console.
- See “Current Weather Mode” on page 15 for information on displaying current weather information.
- See “Troubleshooting and Maintenance” on page 36 for information on troubleshooting console issues and routine maintenance.

Vantage Vue System Installation Steps

- Prepare the Integrated Sensor Suite (ISS) for Installation. See your *Vantage Vue Integrated Sensor Suite Installation Manual*.
- Install, power and set up the console
- Mount the ISS

Chapter 2

Installing the Console

The Vantage Vue console is designed to give extremely accurate readings. As with any precision instrument, use care in its assembly and handling. Although installing the console is relatively simple, following the steps outlined in this chapter and assembling the Vantage Vue correctly from the start will help ensure that you enjoy all of its features with a minimum of time and effort.

Powering the Console

The Vantage Vue console does not require the use of an AC adapter. You may use the included adapter if you wish, but three C-cell batteries (not included) should power a wireless console for up to nine months. You can use either of these or both together, with the batteries providing backup power for the adapter.

Note: The console will display messages if any of your system's batteries are low.
LOW CONSOLE BATTERIES: Replace the console batteries
LOW BATTERY TRANSMITTER (ID#): Replace the battery in your outdoor Integrated Sensor Suite (ISS) or any optional transmitting station you may have added.

Installing Batteries

1. Remove the battery cover located on the back of the console by pressing down on the two latches at the top of the cover.

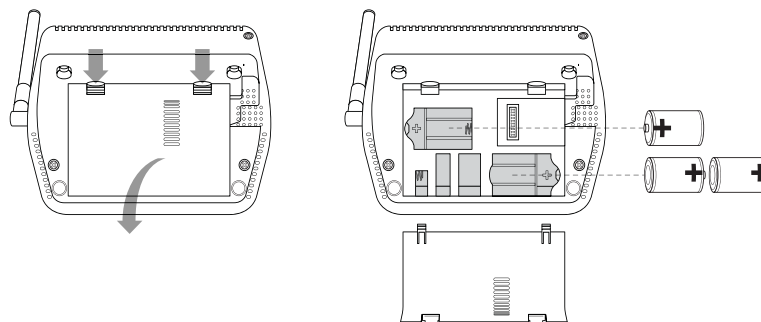

Installing batteries into the Vantage Vue

2. Insert three C batteries into the battery channels as shown.
3. Place the battery cover back onto the console and click it closed.
4. Check to make sure the console runs through a brief self-test procedure successfully.

On power up, the console displays all the LCD segments and beeps three times (four times if you have a data logger plugged in). A message displays at the bottom of the console, followed by the first screen of Setup Mode. Press DONE to skip the message and enter into Setup Mode. Setup Mode guides you through steps required to configure the station. See “Setup Mode” on page 6 for more information.

Note: The console does not recharge the batteries. Because of this, and because NiCad batteries do not power the console as long as alkaline batteries, we do not recommend using NiCad batteries.

Installing the AC Power Adapter (Optional)

1. Find the power jack located on the left side of the console case.
2. Insert the power adapter plug into the console power jack, then plug the other end of the adapter into an appropriate power outlet.
3. Check to make sure the console runs through a brief self-test procedure successfully. See “Installing Batteries” on page 3 for information on the self-test procedure.

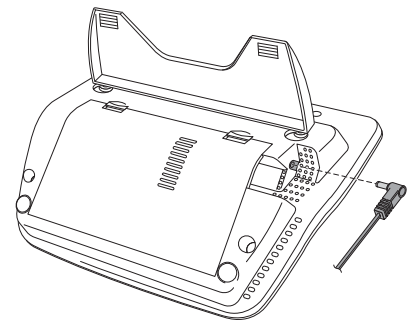

Plugging in the AC adapter

Note: When using an AC power adapter, be sure to use the power adapter supplied with your Vantage Vue console. Your console may be damaged by connecting the wrong power adapter. You must use AC power when using WeatherLinkIP.

Console Location

Place the console in a location where the keyboard is easily accessible and the display is easy to read. For more accurate readings, follow these suggestions.

- Avoid placing the console in direct sunlight. This may cause erroneous inside temperature and humidity readings and may damage the unit.
- Avoid placing the console near radiators or heating/air conditioning ducts.
- If you are mounting the console on a wall, choose an interior wall. Avoid exterior walls that tend to heat up or cool down depending on the weather.
- Avoid positioning a wireless console near large metallic appliances such as refrigerators, televisions, heaters, or air conditioners.
- The console antenna does not rotate in a complete circle. Avoid forcing the console antenna when rotating it.
- Be aware of possible interference from cordless phones or other devices. To prevent interference, maintain a distance of 10 feet (3 meters) between the Vantage Vue console and a cordless phone (handset and base).

Table & Shelf Placement

The console comes with a kickstand so that the console can be displayed on any flat surface. To install the kickstand:

1. Locate the two keyholes on the back of the console.
2. Place the two round tabs on the kickstand into the to keyholes and slide the kickstand up into place.

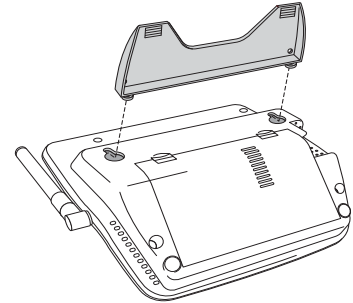

Securing the kickstand

3. Install the two round rubber feet on the bottom of the console.
4. Install the two rubber channel feet on the kickstand.

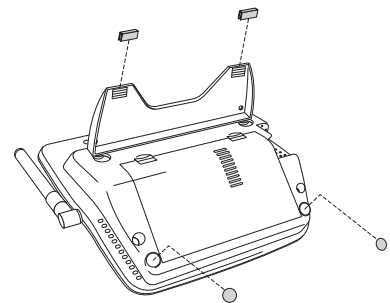

Installing the rubber feet

Wall Mounting

The console mounts to the wall using two keyholes located on the back of the case (the same two keyholes are used to hold the console kickstand in place) and two #6 x 1" pan head self-threading screws included in the hardware kit.

To mount the console on a wall:

1. Use a ruler to mark two mounting hole positions on the wall $4 \frac{15}{16}$ " inches (125 mm) apart. Use the guide holes on the kickstand as a template for the keyhole spacing.
2. Use a drill and a $\frac{3}{32}$ " or $\frac{7}{64}$ " (2.4 or 2.8 mm) drill bit to drill two pilot holes for the screws.
3. Using a screwdriver, drive the two #6 x 1" pan head self-threading screws into the wall. Leave at least $\frac{1}{8}$ " (3 mm) between the wall and the heads of the screws.
4. Guide the two keyholes on the back of the console over the two screws.

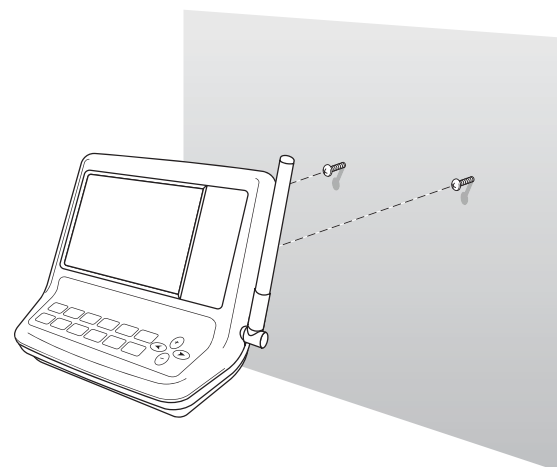

Mounting the console on a wall

Chapter 3

Using Your Weather Station

The console LCD screen and keyboard provide easy access to your weather information. The LCD display shows current and past weather conditions as well as a forecast of future conditions. The keyboard controls console functions for viewing current and historical weather information, setting and clearing alarms, viewing and/or changing station settings, setting up and viewing graphs, and more.

Console Modes

The Vantage Vue console operates in five different modes:

Mode	Description
Setup	Use Setup Mode to enter the time, date, and other information required to calculate and display weather data such as latitude, longitude and elevation. See "Setup Mode" on this page.
Current Weather	Use Current Weather Mode to see current weather information, change measurement units, and to set, clear or calibrate weather readings. See "Current Weather Mode" on page 15.
High/Low	Use High/Low Mode to display the daily, monthly or yearly high and low readings. See "Highs and Lows Mode" on page 30.
Alarm	Use Alarm Mode to set, clear, and review alarm settings for up to 30 different variables/settings. See "Alarm Mode" on page 31.
Graph	Use Graph Mode to display your weather data in the graph section of the console for the current and last 25 time intervals (hours, days, months or even years) in over 50 different graphs. See "Graph Mode" on page 33.

Note: When the console is first powered, or repowered, the Time & Date screen appears. If nothing is done for 10 minutes, the screen will time out and go to the Current Weather screen. (This is true for any setup screen except for the Active Transmitters screen.)

Setup Mode

Setup Mode provides access to the station configuration settings that control how the station operates. Setup Mode consists of a series of screens for selecting console and weather station configuration options.

Setup Mode Commands

Setup Mode displays when the console is first powered. This mode can be displayed at any time to change any of the console options.

Use the following commands to enter, exit and navigate Setup Mode:

- Enter Setup Mode by pressing and releasing 2ND and then SETUP.



- Press DONE to move to the next screen in the Setup Mode.



- Press BAR to display the previous screen in the Setup Mode.
- Press the < and > keys to move to the different segments and options in the Setup Mode screens.
- Press the + and - keys to scroll through the different options available.
- Press 2ND and UNITS to change units of measure when applicable.
- Exit Setup Mode by pressing and holding DONE until the Current Weather screen displays. See “Current Weather Mode” on page 15 for more information.

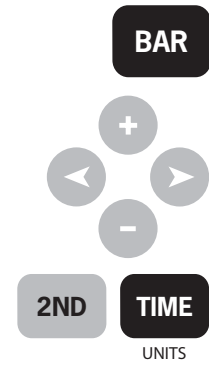

Screen 1: Time & Date

The very first time you power the console, you should enter the correct date and local time. To change the time and date:

1. Press the < and > keys to select the hour, minute, month, day or year segments. The selected time or date setting blinks on and off.
2. Press the + and - keys to adjust a value up or down.

To choose between a 12-hour or 24-hour clock, first select either the hour or minute setting, then press 2ND and immediately press UNITS. This toggles the clock setting between the two clock types.

To choose between a MM/DD or DD.MM display for the date, first select either the day or month setting, then press 2ND and immediately press UNITS. This switches the console from one date display to the other.

3. Press DONE to move to the next screen.

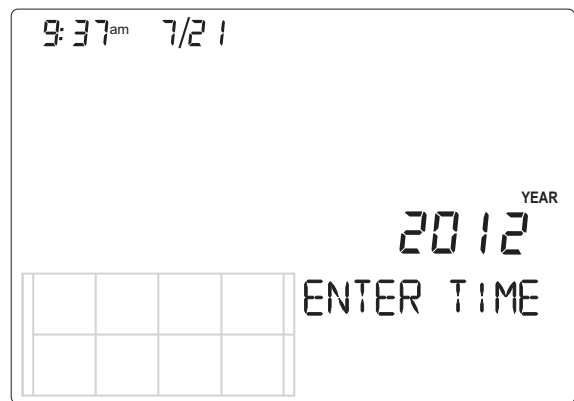

Screen 1: Time & Date

Note: Whenever the console is repowered after power is off or lost, it will open to this screen. This allows you to enter the correct time if needed. If nothing is done after 10 minutes, the screen will time-out and go to the Current Weather screen.

Screen 2: Time Zone

The console is pre-programmed with a combination of US time zones and the names of major cities representing time zones around the world. You can also configure your time zone using the Universal Time Coordinate (UTC, also known as Greenwich Mean Time or GMT) offset.

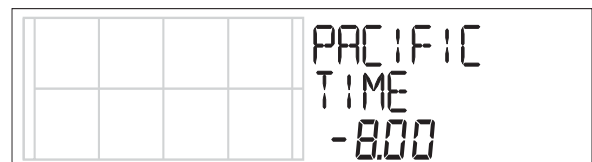

Note: UTC offset measures the difference between the time in any time zone and a standard time, set by convention as the time at the Royal Observatory in Greenwich, England. Hayward, California, the home of Davis Instruments, observes Pacific Standard Time. The UTC offset for Pacific Standard Time is -8:00, or eight hours behind Universal Time (UTC). When daylight saving time is observed, an hour is added to the offset time automatically. Use this function in correlation with “Screen 3: Daylight Saving Settings” on page 8.

1. Press the + and - keys to cycle through time zones.
2. If your time zone is not shown, press 2ND then press the + and - keys to set your UTC offset (UTC offset uses 15 minute increments).
3. Press DONE to select the time zone or UTC offset shown on the screen and move to the next screen.

Screen 3: Daylight Saving Settings

In most of the United States and Canada (except Saskatchewan, Arizona, and Hawaii) and Europe you should use the AUTO Daylight Saving setting. The console is pre-programmed to use the correct starting and stopping dates for daylight saving time in these areas, based on the time zone setting in Screen 2: Time Zone.

Weather stations located outside the United States, Canada, and Europe, or in areas that do not observe daylight saving time should use the MANUAL setting.



1. Press the + and - keys to choose Auto or Manual.
2. Press DONE to move to the next screen.

Screen 4: Daylight Saving Status

Use this screen to either verify the correct automatic daylight saving status or to set daylight saving manually.



1. If the daylight saving setting is MANUAL, press the + and - keys to turn daylight saving time on or off on the appropriate days of the year. This will advance the time by one hour. (Similarly, if you turn daylight saving time off, the time will be set back one hour.)
If you have an AUTO daylight saving setting, the console displays the appropriate setting based on the current time and date.
2. Press DONE to move to the next screen.

Screen 5: Active Transmitters

Screen 5 displays the message “Receiving from...” and shows the ID number of any transmitters being received by the console. The rest of the screen is blank.

If your ISS uses the factory settings and your console is receiving the signal, the screen displays “RECEIVING FROM 1.” The antenna icon displays if any station’s signal has been received. The antenna icon will not display if the console has not received a signal from a station.

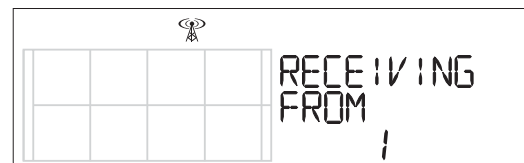

If you have installed a Vantage Pro2 ISS or Anemometer Transmitter kit, or if a nearby neighbor has a Davis weather station, or if you are receiving from another console in retransmit mode, its ID number will also be displayed.

Note: A Vantage Vue or Vantage Pro2 ISS or a Vantage Pro2 Anemometer Transmitter Kit must be powered for the console to recognize it. Refer to the *Integrated Sensor Suite Installation Manual* or other station manual for more information. It may take several minutes for the console to acquire and display a transmitter ID after power is applied to both units.

1. Make a note of the station number(s) listed on the screen.
2. Press DONE to move to the next screen.

Screen 6: Configuring Transmitter IDs

Setup Screen 6 allows you to change the ISS transmitter ID and to add or remove optional transmitter stations.

The default transmitter ID setting is “1 VUE ISS” (refers to a Vantage Vue ISS), which is appropriate for most installations. If you are using only the Vantage Vue ISS with ID 1 press DONE to move to the next screen.



Note: Typically, you can use the default transmitter ID setting of 1 unless a nearby neighbor has a Vantage Pro2 or Vantage Vue station that uses transmitter ID 1.

If you wish to change this default transmitter ID:

1. Press the < and > keys to select a transmitter ID.
 - When you select a transmitter ID (1 - 8), the ID number is displayed on the screen as well as its current configuration (OFF, VUE ISS, VP2 ISS or WIND).
2. Press the + or - keys to toggle console reception of signals from transmitters using that ID on and off.

Note: Make sure any unused ID numbers are set to OFF.

To change the station type for the transmitter ID:

1. Press GRAPH to change the type of station assigned from VUE ISS to VP2 ISS or WIND.
 - **VUE ISS** - Refers to the Vantage Vue ISS (whether direct transmission or retransmission from another console).
 - **VP2 ISS** - Refers to the Vantage Pro2 ISS (whether direct transmission or retransmission from another console).
 - **WIND** - Refers to an optional Anemometer Transmitter Kit (direct transmission only).
2. Press DONE to move to the next screen.

Note: This screen contains functionality for enabling repeaters. If the word “Repeater” displays in the right corner of the screen and you are not using repeaters as part of your network, see “Clearing Repeater ID” on page 51. If you are using repeaters as part of your network see “Wireless Repeater Configuration” (Appendix C) on page 51.

Screen 7: Retransmit

The console can take data it receives from all three station types and retransmit it to other Vantage Vue or Vantage Pro2 consoles using the retransmit feature. By toggling the feature on, the console becomes another transmitter that requires its own unique ID to transmit the data received from the ISS.



1. Press the + or - key to turn the retransmit function on and off. The first available transmitter ID not assigned to a station in Screen 6: Configuring Transmitter IDs will be assigned to the console.

Note: Make sure no other wireless Davis weather station is transmitting on the same ID.

The Vantage Vue console can only retransmit data from either a Vantage Vue ISS or console; or a Vantage Pro2 ISS or console. Data from other stations will not retransmit. When retransmit has already been enabled, pressing the < or > keys changes the transmitter ID used for retransmit.

2. Use the > key to scroll through the list of available transmitter IDs and select the ID for your console.
3. Press DONE to move to the next screen.

Note: Make a note of the ID selected for retransmit and the transmitter type (ISS or VP2) the console is retransmitting. Make sure the console that is receiving the retransmitted data is configured to the correct transmitter type. See "Screen 6: Configuring Transmitter IDs" on page 9 for more information.

Screens 8 and 9: Latitude and Longitude

The console uses latitude and longitude to determine your location, allowing it to adjust the forecast and calculate the times for sunset and sunrise.

- Latitude measures distance north or south of the equator.
- Longitude measures distance east or west of the Prime Meridian, an imaginary line running north and south through Greenwich, England.

If you do not know your latitude and longitude, there are several ways to find out. Many atlases and maps include latitude and longitude lines. You can also talk to the reference department of your local library, call your local airport, or search on the Internet. An easy way to find your latitude and longitude is to download Google Earth (<http://earth.google.com>).

The more accurate you are, the better; however, a reasonable estimate will work, too.

1. Press the < and > keys to move between fields.
2. Press the + and - keys to change the settings up or down.
3. Press 2ND and then UNITS to select between SOUTH or NORTH.
4. Press DONE to move to the Longitude screen.



1. Press the < and > keys to move between fields.
2. Press the + and - keys to change the settings up or down.
3. To select EAST or WEST, press 2ND, then UNITS.
4. Press DONE to move to the next screen.



Screen 10: Elevation

Your station's elevation is used in determining your barometric pressure. Meteorologists standardize barometric pressure data to sea level so that surface readings are comparable, whether they are taken on a mountainside or by the ocean. To use this same standardization and ensure consistent readings, enter your elevation in this screen.



If you do not know your elevation, there are several ways to find out. Many atlases and almanacs include elevation for cities and towns. You can also check with the reference department of your local library, or use Google Maps (in "terrain" view).

The more accurate you are, the better; but a reasonable estimate works too.

1. Press the < and > keys to move from one value to another.
2. Press the + and - keys to adjust a numeral up or down.
3. To switch between feet and meters, press 2ND then press UNITS.
4. If your location is below sea level, such as in Death Valley or the Salton Sea, first enter the elevation as a positive number. Select the "0" immediately to the left of the left-most non-zero digit (the second zero from the left in 0026, for example, or the first zero from the left in 0207) and press and hold the + or - key until it cycles from 0 to 9 and then -.

Note: You can only set the elevation to negative after you have entered a non-zero digit and when the zero in the position immediately to the left of the left-most non-zero digit has been selected. If you need to enter an elevation below -999 feet, select meters and enter the converted number (multiply your elevation in feet by 0.3048).

5. Press DONE to move to the next screen.

Screen 11: Barometric Reduction Setting

The Barometric Reduction Setting screen indicates the method by which barometric pressure is to be determined and calculated. The factory default is NOAA, but in this screen you may select a different method.

To change the barometric reduction setting:

1. Press + or - to change the barometer reduction setting type:

- **NOAA (Default Setting)** — The barometer is reduced to sea level using a technique that factors in the humidity and temperature of the column of air.
- **ALT SETTING (Altimeter Setting)** — The barometer is reduced to sea level using a “standard” column of air, often referred to as a “standard atmosphere.”
- **NONE** — Reports a raw barometric pressure reading unadjusted for elevation/altitude.

2. Press DONE to move to the next screen.



Note: See “Calibrating Barometric Pressure” on page 28 to learn how to fine-tune your barometric pressure to a local source.

Screen 12: Wind Cup Type (Optional)

The Wind Cup Type screen displays if you selected VP2 or WIND in Screen 6 of the Setup Mode. This screen does not display if you have selected a Vantage Vue ISS. See “Screen 6: Configuring Transmitter IDs” on page 9 for more information.

The Wind Cup Type screen contains three options: LARGE, SMALL, or OTHER. In most Vantage Pro2 anemometer or ISS Installations, LARGE is the cup type that is shipped with all Vantage Pro2 anemometers. See the *Vantage Pro2 Console Manual* for more information.

To change the wind cup type:

1. Press the + and - keys to scroll through the three wind cup options.
2. Press DONE to use the selected setting and move to the next screen.



Note: Do not change the wind cup type from LARGE if you are using the wind cups that were shipped with your system.

Screen 13: Rain Collector

The tipping spoon in the Vantage Vue rain collector has been calibrated at the factory to measure either 0.01" or 0.2mm of rain with each tip depending on the model. This screen is used at the factory for this calibration. The typical user will not need to change it and can skip this screen.



Note: This screen will not change the units on your display. To change the units on your display from inches to mm, or vice versa, see “Selecting Units of Measure” on page 26.

Screen 14: Rain Season

Because rainy seasons begin and end at different times in different parts of the world, you must specify the month you wish your yearly rain data to begin. January 1st is the default setting.

The date the rain season begins affects yearly rain rate highs and lows as well as the yearly rain totals.



1. Press the + and - keys to select the month for the start of the rainy season.
2. Press DONE to move to the next screen.

Note: This setting determines when the yearly rain total is reset to zero. Davis Instruments recommends a January rain season setting (the default), unless you reside on the west coast of the United States, the Mediterranean Coast, or experience dry winters in the southern hemisphere. If so, change the rain season setting to July 1st. If you are performing hydrology studies in any of these climates in the Northern Hemisphere, change the rain season setting to October 1st.

Screens 15 and 16: Cooling and Heating Degree Day Base

The Cooling and Heating Degree Day Base screens let you determine the temperature base that is used to calculate the number of cooling or heating degree days. A cooling degree day is used to determine the amount of energy or fuel used to keep a structure like your home or business cool. A heating degree day is used to determine the amount of energy or fuel used to keep a structure like your home or business warm.

One cooling degree/day is the amount of cooling required to keep a structure cool when the outside temperature remains 1°F **above** the 65°F threshold for 24 hours. One cooling degree/day is also the amount of cooling required when the temperature remains 24°F above the 65°F threshold for one hour.

One heating degree/day is the amount of heat required to keep a structure warm when the outside temperature remains 1°F **below** the 65°F threshold for 24 hours. One heating degree/day is also the amount of heat required when the temperature remains 24°F below the 65°F threshold for one hour.

The cooling and heating degree days (similar to growing degree days and chilling requirement in agriculture) are used for agricultural purposes, as well as for energy use analysis. Our optional WeatherLink software (#6510USB, 6510SER, 6555) calculates degree day totals. Our optional Agricultural/Turf Management Software Module (#6511) adds the special reporting features to the WeatherLink software that include evapotranspiration and chilling requirement.

The Cooling and Heating Degree Day Bases are used to determine the Cooling Degree Day Daily Total and Heating Degree Day Daily Total, which display as part of the Weather Center when the outside temperature variable is selected. See “Inside and Outside Temperature” on page 18 for more information.

A base setting for both the Cooling and Heating Degree Day temperature is not set at the factory, allowing you to choose. A base of 65°F (15°C in Europe) is suitable for most applications.

To set your cooling degree day base:

1. Press 2ND and SET. The value of 65° appears. Use the < and > keys to select a segment of the value.
2. Press the + and - keys to adjust the value of the selected segment.
3. Press 2ND and UNITS to change the temperature setting between Fahrenheit and Celsius.
4. Press DONE to move to the next screen.

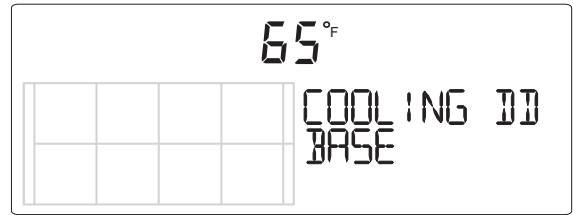

The Heating Degree Day Base displays:

To set your heating degree day base, follow steps 1 through 4 above.

To turn the degree day function off, press 2ND and then clear. The value changes to dashes.

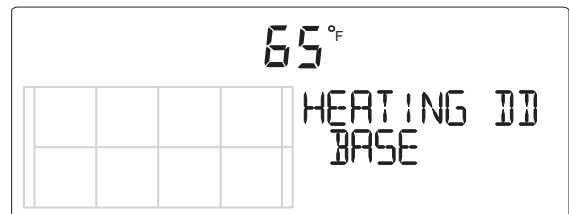

Note: If a base temperature is displayed, degree day data is being accumulated. If the value shows dashes, the degree day function is off and will not appear in the Weather Center.

Screens 17 and 18: Commentary and Key Beep

Commentary refers to the extra information and comments on current weather conditions, such as lunar and solar eclipses, meteor showers and other information, that displays on the console in the Weather Center.

Key Beep is a sound that indicates a key has been pressed. (It is different from the “error” sound. To change this sound, See “Changing Alarm Sound” on page 33.)

These functions can be turned off or on.

1. Press the + and - keys to toggle the setting to OFF or ON.
2. Adjust key beep volume using the < and > keys.
3. Press DONE to move to the next screen.

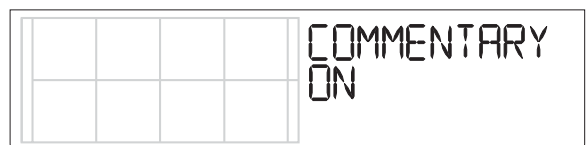

Screen 19: Baud Rate (Optional)

The Baud Rate screen displays only if a WeatherLink data logger is installed in the console. The console uses a serial, USB, or Ethernet port to communicate with a computer. If you are connecting the console directly to your computer via USB or Ethernet connection, leave the setting at 19200, the highest rate for the port.

Note: The baud rate setting on your console must match the baud rate setting in the software on your computer. If you are using WeatherLink for Vantage Vue, refer to WeatherLink Help for instructions on setting the serial port baud rate on your computer.

1. Press the + and - keys to select the baud rate.
Your Vantage Vue console supports baud rates of 1200, 2400, 4800, 9600, 14400, and 19200.
2. Press DONE to save the baud rate settings.

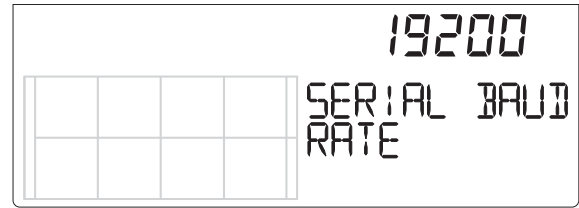

Exiting Setup Mode

You have successfully completed all the screens in the Setup Mode. To exit Setup Mode, press and hold DONE for several seconds until the Current Weather screen appears.

Clear All Command

After you have completed the above set up procedures and have exited the Setup Mode and once the Vantage Vue ISS, Vantage Pro2 ISS or Anemometer Transmitter kit has been installed, use the Clear All command before putting your weather station into service.

The Clear All command clears all stored high and low weather data including monthly and yearly highs and lows, and clears the alarm settings. The command is recommended to properly clear the console of any erroneous data when first putting your station into use.

1. Press WIND to display wind speed on the console.
2. Press 2ND, then press and hold CLEAR for at least six seconds.
3. Release CLEAR when you see "CLEARING NOW" displayed at the bottom of the console's screen.

Current Weather Mode

In the Current Weather Mode you can display the current data readings from your station, select units of measure, and calibrate, set, or clear weather variables.

You can see up to eight weather variables on the screen at the same time, as well as the time and date, moon phase and forecast icons, and a graph of the currently selected variable.

Some variables are always visible on the console screen while most variables share their location with one or more variables. You can select any variable not currently on the screen to display it.

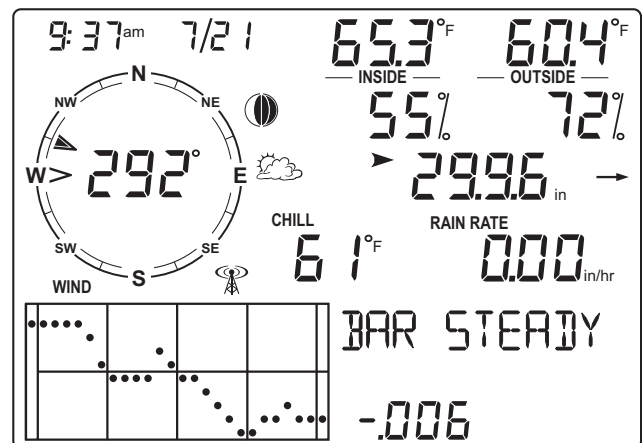

Current Weather Mode Commands

Select a weather variable to display its data on the screen if it isn't already visible, or to graph the data available for that variable.

Weather variables are selected via the console command keys:

- If the variable is printed on a key, press the key to select the variable.



- The same field can display multiple values for each variable. Press the variable key to scroll through all the values
- Multiple variables may share the same field on the display.

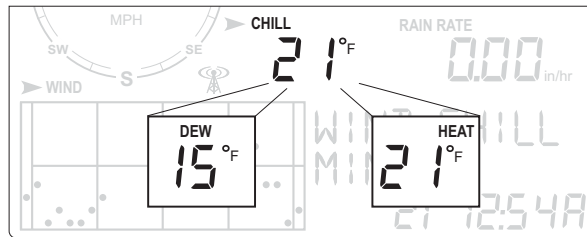

Wind chill, dew point, heat index share the same field in Current Weather Mode

- If a variable is printed above or below a key, first press and release 2ND, then quickly press the key below the printed variable to select that variable.

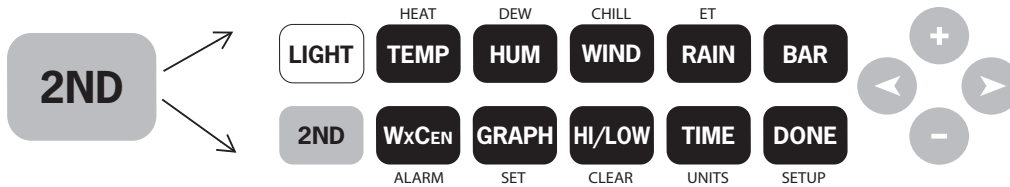

After pressing 2ND, the **2nd** icon displays on the screen for eight seconds. Key secondary functions are enabled during this time. The keys return to normal operation after the icon disappears.

- Select a variable and press WxCEN to display information pertinent to the selected variable in the Weather Center. Continue to press WxCEN to scroll through all the information available for the variable.
- You can also select any variable currently displayed on the LCD screen using the navigation keys. Press the + key to move the selection arrow up the screen. Press the - key to move it down the screen. Push the < key to move it left and push the > key to move it right.



Displaying Weather Variables

The variables are arranged below in the order they are viewed on the console screen; left to right, top to bottom, starting with Time and Date.

Time and Date, Sunrise and Sunset Time, Moon Phase, Forecast Icons

The time and date display in the upper left hand corner of the console screen, above the wind compass rose.

- Press **TIME** to display the sunrise and sunset time for the current day. Press **TIME** again to redisplay the time and date.



The phase of the moon is described in the Weather Center section of the console when the sunrise and sunset times are displayed. The moon phase icon corresponds to the moon phase description in the Weather Center. See “Moon Phases” on page 42.

The current forecast icon displays underneath the current moon phase icon. The forecast icons show what weather conditions may occur within the next 12 hours. See “Forecast” on page 43 for more information on the forecast icons and descriptions of the forecasted weather they represent.

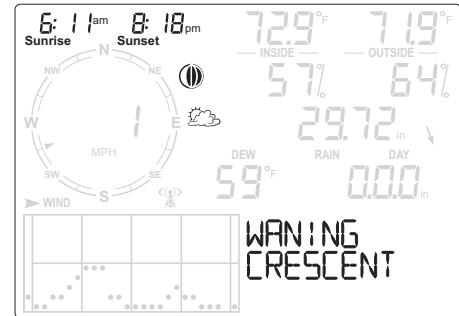

Sunrise and sunset times, moon phase and forecast icons, with the moon phase listed in the Weather Center

Note: See “Screen 1: Time & Date” on page 7 to change the console time and date or to select a 12- or 24-hour clock.

Wind Speed and Direction

Wind speed and direction are displayed in the compass rose in the upper left section of the console screen:

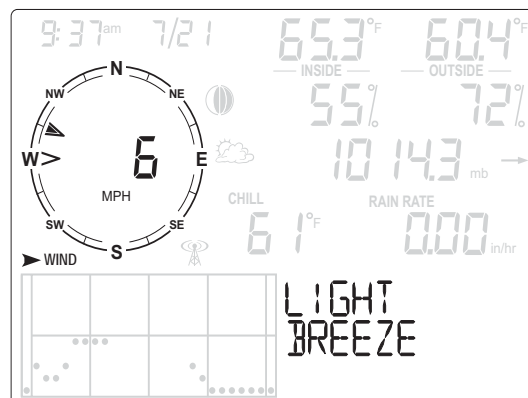

Wind speed, direction and wind information displayed in the Weather Center

1. Press **WIND** to select wind speed.

Wind speed may be displayed in miles per hour (MPH), kilometers per hour (km/h), meters per second (m/s), or knots. See “Selecting Units of Measure” on page 26 for more information on changing the unit of measure. The graph will show the current and last 25 hours of readings.



A solid arrow within the compass rose indicates the current wind direction. Open arrows indicate up to six different 10-minute dominant wind directions to provide a history of the dominant wind directions for the past hour.



2. Press WIND a second time to display the wind direction in degrees instead of the wind speed.

Each additional WIND key press toggles the display between wind speed and wind direction in degrees. When displayed in degrees, due north displays as 360°.

If the solar panel on your ISS is not facing due south, you should recalibrate the wind direction reading on your console. See “Calibrating Wind Direction Reading” on page 27.

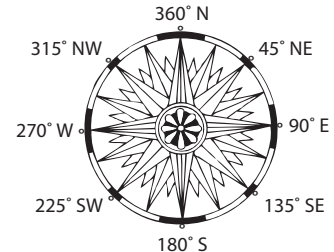

3. Press WxCEN to display the weather information available for wind in the Weather Center.
4. Press WxCEN multiple times to scroll through all the wind-related Weather Center screens, which include:
 - **Maximum Wind Speed** — Displays the highest wind speed recorded for the day. Includes the time the speed was recorded.
 - **Last 10 Minute Gust** — Displays the high wind gust in the last 10 minutes with the direction of the highest gust displayed in degrees.
 - **Average Wind Speed** — Displays the average speed over the past two minutes and over the past ten minutes.
 - **Beaufort Scale** — Toggles between a description of the wind speed and how the wind ranks on the Beaufort Scale. (See “Beaufort Scale” on page 44 for more information.)
 - **Wind Direction** — Displays the current wind direction in degrees.

Inside and Outside Temperature

Inside and outside temperature are displayed in the top right portion on the console screen. The inside temperature is located above the word INSIDE and the outside temperature is located above the word OUTSIDE.

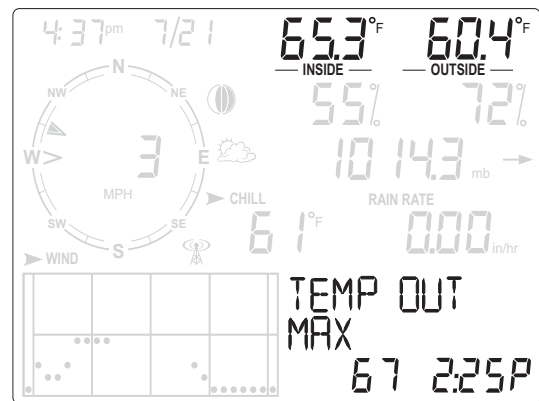

Inside and outside temperature with information displayed in the Weather Center

1. Press TEMP to select the outside temperature.

Temperature may be displayed in degrees Fahrenheit (°F) or Celsius (°C). Temperatures can also be displayed in degrees or in tenths of a degree. See “Selecting Units of Measure” on page 26 for more information on changing the unit measure or displaying the temperature in tenths of a degree. If the unit of measure



is changed for inside or outside temperature, the unit of measure also changes for all temperature-related weather variables, such as wind chill, dew point and heat index.

Note: The unit of measure also affects the cooling degree day and heating degree day bases and the value entered in both screens is automatically converted to the unit of measure selected. Check the values for both of these bases in the Setup Mode to make sure the value is still accurate for the new unit of measure. See “Screens 15 and 16: Cooling and Heating Degree Day Base” on page 13 for more information.

2. Press WxCEN to display weather information available for the outside temperature variable in the Weather Center.
3. Press WxCEN multiple times to scroll through all the outside-temperature-related Weather Center screens, which include:
 - **Maximum Temperature** — Displays the highest temperature for the day with the time the temperature was recorded.
 - **Minimum Temperature** — Displays the lowest temperature for the day with the time the temperature was recorded.
 - **Temperature Change Per 24 Hours** — Displays the difference between the temperature currently recorded and the temperature recorded at the same time the day before. (Updated on the hour.)
 - **Temperature Change Per Hour** — Displays the difference between the temperature currently recorded and the temperature recorded the hour before. (Updated every 15 minutes.)
 - **Maximum Outside Temperature Today and Over the Last 25 days** — Displays the highest temperature today and over the last 25 days and the date the temperature was recorded.
 - **Minimum Outside Temperature Today and Over the Last 25 days** — Displays the lowest temperature today and over the last 25 days and the date the temperature was recorded.
 - **Number of Cooling Degree Days** — Displays the number of cooling degree days logged on the console since it was first powered up or the value was reset. (Displays only if a threshold has been set.)
 - **Number of Heating Degree Days** — Displays the number of heating degree days logged on the console since it was first powered up or the value was reset. (Displays only if a threshold has been set.)
4. Press TEMP again to select the inside temperature.
5. Press WxCEN to display the weather information available for the inside temperatures in the Weather Center.
6. Continue pressing WxCEN to scroll through all the inside-temperature-related Weather Center screens, which include:
 - **Maximum Temperature** — Displays the highest inside temperature for the day with the time the temperature was recorded.
 - **Minimum Temperature** — Displays the lowest inside temperature for the day with the time the temperature was recorded.

Humidity

Inside and outside humidity are displayed in the top right portion on the console screen, below the temperature variables. The inside humidity is located below the word INSIDE and the outside humidity is located below the word OUTSIDE.

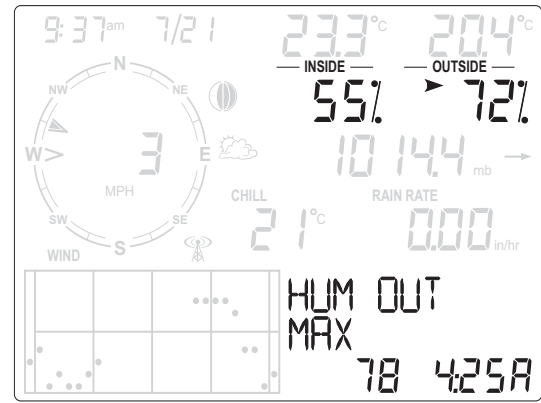

Inside and outside humidity with information displayed in the Weather Center

1. Press HUM to select outside humidity. Humidity is displayed in percent relative humidity. HUM
2. Continue pressing WxCEN to display the information available for outside humidity in the Weather Center and to scroll through the outside humidity-related Weather Center screens, which include:
 - **Maximum Outside Humidity** — Displays the highest humidity measurement for the day and the time it was recorded.
 - **Minimum Outside Humidity** — Displays the lowest humidity measurement for the day and the time it was recorded.
3. Press HUM a second time to select inside humidity.
4. Press WxCEN to display the information available for inside humidity in the Weather Center. Continue pressing WxCEN to scroll through the inside humidity-related Weather Center screens, which include:
 - **Maximum Inside Humidity** — Displays the highest inside humidity measurement for the day and the time it was recorded.
 - **Minimum Inside Humidity** — Displays the lowest inside humidity measurement for the day and the time it was recorded.

Barometric Pressure

Barometric pressure and pressure trend display below inside and outside humidity.

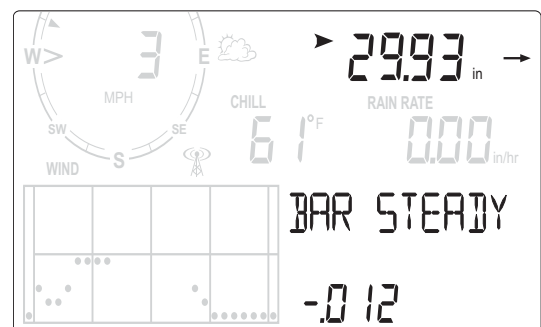

Barometric Pressure with information displayed in the Weather Center

1. Press BAR to select barometric pressure. Barometric pressure may be displayed in inches (in), millimeters (mm), millibars (mb) or hectoPascals (hPa). See “Selecting Units of Measure” on page 26 for more information on changing the unit measure. BAR
2. Press WxCEN to display the information available for the barometric pressure trend in the Weather Center.

3. Continue pressing WxCEN to scroll through all the barometric pressure-related Weather Center screens, which include:
 - **Barometric Pressure Change Per 24 hours** — Displays the difference between the barometric pressure currently recorded and the barometric pressure recorded at the same time yesterday. (Updated on the hour.)
 - **Maximum Barometric Pressure** — Displays the highest barometric pressure reading for the day and the time the measurement was recorded.
 - **Minimum Barometric Pressure** — Displays the lowest barometric pressure reading for the day and the time the measurement was recorded.
 - **Altimeter Setting** — Displays the barometric pressure that would display if “ALT SETTING” was selected in Screen 11: Barometric Reduction Setting. The barometric pressure reading and the altimeter setting reading will be the same if the altimeter setting was selected. See “Screen 11: Barometric Reduction Setting” on page 12 for more information.
 - **Absolute Pressure** — Displays the barometric pressure that would display if “NONE” was selected in Screen 11: Barometric Reduction Setting. The barometric pressure reading and the absolute pressure reading will be the same if none was selected. See “Screen 11: Barometric Reduction Setting” on page 12 for more information.
 - **Barometric Pressure Trend** — Describes the current barometric trend and the numeric change in the barometric pressure over the last three hours. The barometric pressure trend listed in the Weather Center corresponds to the pressure trend arrows displayed next to the barometric pressure variable. The trends are:
 - **Bar Rising Rapidly** — Refers to a rise in pressure greater than or equal to 0.06" (2 hPa) over the last three hours.
 - **Bar Rising Slowly** — Refers to a rise in pressure greater than or equal to 0.02" (0.7 hPa) but less than 0.06" (2 hPa) over the last three hours.
 - **Bar Steady** — Refers to no change or a change of less than 0.02" (0.7 hPa) either rising or falling over the last three hours.
 - **Bar Falling Slowly** — Refers to a fall in pressure greater than or equal to 0.02" (0.7 hPa) but less than 0.06" (2 hPa) over the last three hours.
 - **Bar Falling Rapidly** — Refers to a fall in pressure greater than or equal to 0.06" (2 hPa) over the last three hours.

Pressure Trend

The pressure trend arrow indicates the current barometric trend, measured over the last three hours. The pressure trend is updated every 15 minutes. The pressure trend requires three hours of data in order to be calculated so it won't display right away on a new station. The pressure trend is indicated on the console screen, as long as the required data is available.

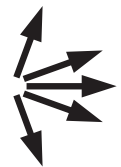

Wind Chill

Wind chill shares the same section on the console as dew point and heat index, below the barometric pressure variable, next to the wind compass rose.

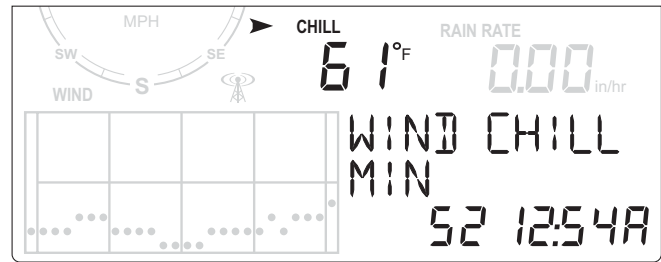

Wind chill with information displayed in the Weather Center

1. Press 2ND then press CHILL to select wind chill. Wind chill is displayed in either Fahrenheit (°F) or Celsius (°C) in whole degrees. See “Selecting Units of Measure” on page 26 for more information on changing the unit of measure.



If the unit of measure for any temperature-related weather variable is changed, the unit of measure also changes for all temperature-related variables. See “Inside and Outside Temperature” on page 18 for more information.

The console uses the ten-minute average wind speed to calculate wind chill.

2. Press WxCEN to display the weather information available for wind chill in the Weather Center.
3. Press WxCEN twice to scroll through the wind chill-related Weather Center screens, which include:
 - **Minimum Wind Chill** — Displays lowest wind chill measurement for the day and the time it was recorded.
 - **Maximum Wind Speed** — Displays the maximum wind speed for the day and the time it was recorded.

Dew Point

Dew point (outside only) shares the same section on the console as wind chill and heat index, below the barometric pressure variable, next to the wind compass rose.

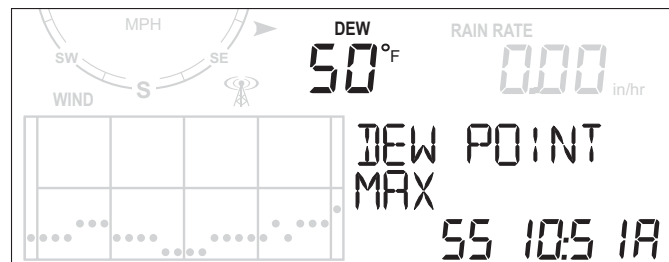

Dew Point with information displayed in the Weather Center

1. Press 2ND then press DEW to select dew point. Dew point is displayed in either Fahrenheit (°F) or Celsius (°C) in whole degrees. See “Selecting Units of Measure” on page 26 for more information on changing the unit of measure.



If the unit of measure for any temperature-related weather variable is changed, the unit of measure also changes for all temperature-related variables. See “Inside and Outside Temperature” on page 18 for more information.

2. Press WxCEN to display the weather information available for dew point in the Weather Center. Press WxCEN twice to scroll through the Weather Center screens, which include:
 - **Maximum Dew Point** — Displays the highest dew point measurement for the day with the time it was recorded.
 - **Minimum Dew Point** — Displays the lowest dew point measurement for the day with the time it was recorded.

Heat Index

Heat index (outside only) shares the same section on the console as wind chill and dew point, below the barometric pressure variable, next to the wind compass rose.

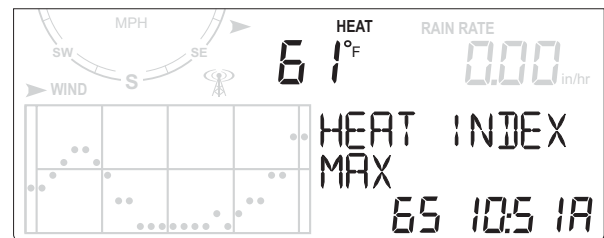

Heat Index with information displayed in the Weather Center

Press 2ND then press HEAT to display the heat index. Heat index is displayed in either Fahrenheit (°F) or Celsius (°C) in whole degrees.



See “Selecting Units of Measure” on page 26 for more information on changing the unit of measure. If the unit of measure for any temperature-related weather variable is changed, the unit of measure also changes for all temperature-related variables. See “Inside and Outside Temperature” on page 18 for more information.

The Maximum Heat Index (the highest Heat Index measurement recorded for the day) along with the time it occurred displays in the Weather Center section of the console.

Rain

All the rain values are displayed in the same section on the console below the barometric pressure variable, on the right side.

The rain values include RAIN RATE, RAIN DAY (current day's rain total), RAIN MO (monthly rain total), and RAIN YEAR (yearly rain total).

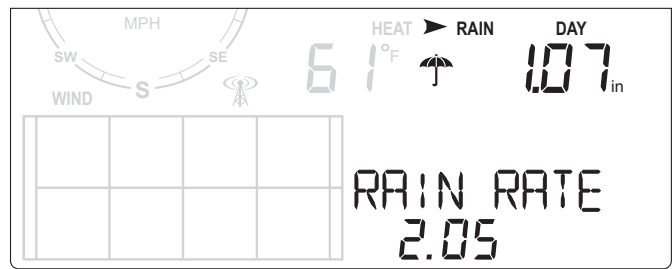

Daily Rain Total with information displayed in the Weather Center

1. Press RAIN to display the current rain rate.



Rain rate will display a number other than zero and the umbrella icon appears when two tips of the rain spoon have occurred within a 15-minute period.



2. Press RAIN again to display RAIN DAY, the rain accumulated since 12:00 midnight.
3. Press RAIN a third time to select the month-to-date precipitation data. Monthly rain displays the precipitation accumulated since the calendar month began.
4. Press RAIN a fourth time to display the year-to-date precipitation data. Yearly rain displays the precipitation accumulated since the first of the month you've chosen as the beginning of your rain season in Setup Mode. (See "Screen 14: Rain Season" on page 13.)

All rain measurements may be displayed as either inches per hour (in/hr) or millimeters per hour (mm/hr). See "Selecting Units of Measure" on page 26 for more information on changing the unit of measure.

5. Press WxCEN to display the weather information available for all of the rain variables in the Weather Center.
6. Press WxCEN multiple times to scroll through the rain-related Weather Center screens, which include:
 - **Rain Rate** — Displays the current rate of rain (unless already displayed).
 - **Rain Rate Maximum** — Displays the maximum rain rate for the day and the time the rate occurred.
 - **Rain Last 15 Minutes** — Displays the total amount of rain recorded over the last 15 minutes.
 - **Rain Last 24 Hours** — Displays the total amount of rain recorded over the last 24 hours.
 - **Rain Day** — Displays rain since midnight (unless already displayed).
 - **Last Storm** — Displays the rain total from the last rain event and the date on which the most recent storm ended. It takes two tips of the rain spoon to begin a storm event and 24 hours without rain to end a storm event.
 - **Rain Last __ Days** — Displays the total rain amount over a user-selected number of days. To change the number of days over which the total rain amount is displayed, press the + and - keys when this screen is displayed in the Weather Center. The number of days allowable is 26 (the last 25 days plus the current day).

Evapotranspiration (ET) (Optional)

All the evapotranspiration values share the same section on the console as rain values, below the barometric pressure variable, on the right side.

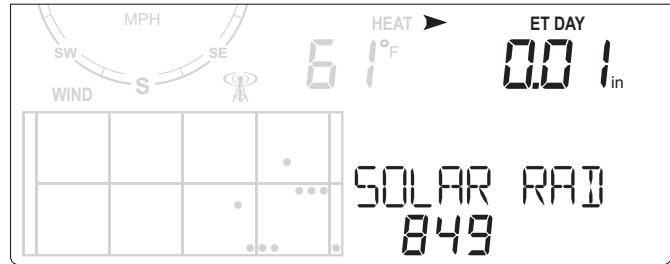

Daily Evapotranspiration with Solar Radiation information displayed in the Weather Center

Note: Evapotranspiration, solar radiation and UV index measurements are available only when the Vantage Vue console is “listening to” a Vantage Pro2 Plus ISS or other Vantage Pro2 ISS in which a solar radiation (and a UV sensor, for UV index) has been installed and “VP2 ISS” has been selected in Screen 6 of the Setup Mode. See “Screen 6: Configuring Transmitter IDs” on page 9.

1. Press and release 2ND then press ET to display the daily evapotranspiration reading.



Note: If you hear an error beep when selecting ET, it means the station the console is selected to “hear” is not a Vantage Pro2 station with a solar radiation sensor.

2. Press and release 2ND then press ET again to display the monthly evapotranspiration reading.
3. Press and release 2ND then press ET a third time to display the evapotranspiration reading since January 1st of the current year.
4. Press WxCEN to display the weather information available for all of the ET variables in the Weather Center.
5. Press WxCEN multiple times to scroll through the ET-related Weather Center screens, which include:
 - **ET Last __ Days** — Displays the total ET amount over a user-selected number of days. To change the number of days over which the total ET amount is displayed, press the + and - keys when this screen is displayed in the Weather Center. The number of days allowable is 26 (the last 25 days plus the current day).
 - **Solar Radiation** — Displays the current solar radiation measurement for the day.
 - **UV Index** — Displays the current UV index.

Weather Center

Press WxCEN to view added information in the Weather Center section of the console for each variable. See each individual variable for a list of Weather Center screens available for each variable.



Light

Press LIGHT to turn on the backlight for the screen display. Press LIGHT again to turn the backlight off.



Use the backlight when the LCD is not clearly visible. When the console is battery operated, the backlight remains on as long as keys are being pressed. If no keys are being used, the backlight automatically turns off about fifteen seconds after it is turned on. If any key is pressed while it is turned on, it will stay illuminated for 60 seconds from the last key press. When battery power is low, the backlight does not light.

Note: When the console receives power from the AC adapter, the backlight remains on until it is toggled off. **Leaving the backlight on for an extended period of time raises the inside temperature reading and lowers the inside humidity reading.**

To adjust the screen's contrast, press and release 2ND then press the + and - keys multiple times while the 2nd icon appears on the screen. The + key darkens the segments currently displaying on the console screen. The - key lightens the segments currently displaying on the console screen. Adjust the contrast as desired.

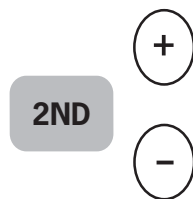

Note: The step changes are subtle. You may need to press the keys several times.

Selecting Units of Measure

Most weather variables may be displayed in at least two different measurement units, including US and metric systems, although some variables feature more possibilities. Barometric pressure, for example, may be displayed in millibars, millimeters, inches, or hectoPascals. You can change each variable's units independently and at any time.

To change units:

1. Select the weather variable.
2. Press and release 2ND then press UNITS.

The selected variable's units change. Repeat steps 1 and 2 until the desired units appear.



For example, to change the barometric pressure units, first select barometric pressure by pressing BAR. Next, press and release 2ND, then press UNITS. Repeating these steps cycles through the units available for barometric pressure: inches, millimeters, hectoPascals, and millibars.

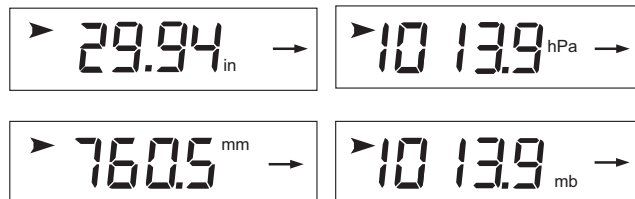

Displaying barometric pressure units:
inches (in), millimeters (mm), hectoPascals (hPa) and millibars (mb)

Calibrating, Setting, and Clearing Variables

Your Vantage Vue weather station is factory-calibrated and tested to be highly accurate. You should not need to calibrate it. However, to fine-tune your station, you can calibrate most of the weather variables. For example, if your outside temperature seems consistently too high or too low, you can enter an offset to correct the deviation.

Calibrating Temperature and Humidity

You can calibrate inside and outside temperature, and inside and outside humidity on your Vantage Vue.

1. Select the temperature or humidity variable to be calibrated.
2. Press and release 2ND, then press and hold SET.



After a moment, the variable you've selected will begin to blink. Keep holding SET until the Calibration Offset message displays in the Weather Center.

3. Press the + or - keys to add or subtract from the temperature offset value.

Inside and outside temperature are calibrated in 0.1° F or 0.1° C increments, up to a maximum offset of +/- 12.7 (°F or °C). The variable's value will change and the Weather Center shows the offset you have entered.

4. Press DONE to exit calibration.

Calibrating Wind Direction Reading

The wind vane on your ISS is calibrated at the factory to be accurate when the solar panel above it is pointing south. If your solar panel does not point south, you must use this procedure to correct the wind direction. In any case, you can also use this procedure to fine-tune your station for greatest accuracy.

Note: Wind direction calibration should be done when the ISS is mounted in its final position and the vane is still.

1. With the wind vane stationary, ascertain its actual direction. Compare it to the direction reading on the console.
2. Press WIND until the wind direction in degrees is displayed.
3. Press and release 2ND, then press and hold SET. The wind direction variable will begin to blink.
4. Continue holding SET until "CAL" displays in the Weather Center. The Weather Center displays the previously set wind direction calibration value, if one has been set.
5. Change the value of the wind direction in the compass rose based on the direction the anemometer is currently pointing. Due north is 360°, east is 90°, south is 180° and west is 270°.
6. Press the < and > keys to select digits in the anemometer's current reading.
7. Press the + and - keys to set the correct reading.
8. Press DONE to exit calibration.

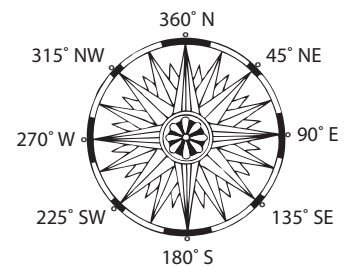

Note: Wind direction can not be corrected by repositioning the wind vane.

Calibrating Barometric Pressure

Before calibrating the barometric pressure, be sure the station is set to the correct elevation. See “Screen 10: Elevation” on page 11 for more information. Find the nearest source of barometric pressure, such as a local airport, to get a current barometric pressure.

1. Press BAR to select barometric pressure.
2. Press and release 2ND, then press and hold SET. The barometric pressure variable blinks.
3. Continue holding SET until the Weather Center reads “SET BAR.”
4. Press the < and > keys to select digits in the variable.
5. Press + and - keys to add to or subtract from the digit’s value.
6. Press DONE to exit calibration.

Calibrating Rain

The Rain Error in Percent refers to the measuring error of your rain collector. To set the rain error percentage, first determine the percentage of error, then:

1. Enter Setup Mode by pressing 2ND and then SETUP.
2. Press DONE multiple times until Screen 13: Rain Collector displays. (See “Screen 13: Rain Collector” on page 12 for more information.)
3. Press and release 2ND and then press and release SET to display the RAIN ERROR IN PERCENT screen.

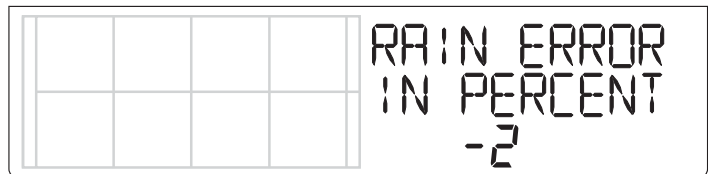

Rain Error in Percent

4. Enter the error. Enter a negative number if your station is under-reporting; enter a positive number if it is over-reporting. For example, if your station is low by 2%, enter -2. If your station is high by 4%, enter 4. Press the + and - keys to add or subtract from the percent amount. The Rain Error Percentage range is -25 to 25 percent. (Not all corrections are available, so you may have to choose the closest one.)
5. Press and hold DONE to save the setting and exit Setup Mode.

Note: This calibration will not retroactively affect past rain totals. It will only affect future rain data.

Setting Weather Variables

Setting a weather variable allows you to manually enter a total for that weather variable that accrued prior to installation of your weather station.

You can set values for the following weather variables:

- **Daily Rain** — Sets the daily rain total. Monthly and yearly rain totals are updated.
- **Monthly Rain** — Sets the total rain for the current month. Does not affect the yearly rain total.
- **Yearly Rain** — Sets the current year’s rain total.
- **Daily ET (Evapotranspiration)** — Sets the daily ET total. Monthly and yearly ET totals are updated.
- **Monthly ET** — Sets the current month’s ET. Does not affect yearly total.
- **Yearly ET** — Sets the current year’s total ET.

To set a weather variable's value:

1. Select the variable you wish to change (either RAIN or ET).
2. Press and release 2ND, then press and hold SET. The variable blinks.
3. Keep holding SET until all digits are lit and stop flashing. Release SET; only one digit is now blinking.
4. Press the < or > keys to select digits in the value.
5. Press the + and - keys to add to or subtract from the selected digit.
6. When you are finished, press DONE to exit.

Clearing Weather Variables Accumulations & Calibrations

The following weather variables can be cleared:

- **Wind Direction**—Clears the wind direction calibration.
- **Barometer** — Clears any pressure offset used to calibrate the station.

Note: Clearing the barometric pressure offset value also clears the elevation setting in Setup Mode. See "Screen 10: Elevation" on page 11.

- **Daily rain**—Clearing the daily rain value is reflected in the daily rain total, the last 15 minutes of rain, the last three hours of rain sent to the forecast algorithm, the umbrella icon, and the monthly and yearly rain totals. Clear the daily rain total if the station accidentally recorded rain when the ISS was installed or after routine cleaning and maintenance.
- **Monthly rain** — Clears the monthly rain total. Does not affect the yearly rain total.
- **Yearly rain** — Clears the yearly rain total.
- **Daily ET** — Clears daily ET and subtracts the old daily ET total from the monthly and yearly ET totals.
- **Monthly ET** — Clears the current monthly ET total. Does not affect the yearly ET total.
- **Yearly ET** — Clears the current yearly ET total.
- **Heating and Cooling Degree Days**— Clears the accumulated degree day total.

To clear a single weather variable:

1. Select the weather variable. (For degree days, select outside temperature, press WxCtr until degree days is displayed.)
2. Press and release 2ND, then press and hold CLEAR.

The variable you've chosen blinks. Keep holding CLEAR until the value changes to zero or, in the case of the barometer, the raw barometer value.



Clear All Command

This command clears all stored high and low weather data, including monthly and yearly highs and lows, and clears alarm settings all at once.

1. Press WIND, making sure wind speed is displayed.
2. Press 2ND then press and hold CLEAR for at least six seconds.
3. Release CLEAR when "CLEARING NOW" displays at the bottom of the screen.

Highs and Lows Mode

The Vantage Vue records highs and lows for many weather conditions over three different periods: days, months, and years. Except for yearly rainfall, all high and low registers are cleared automatically at the end of each period.

For example, daily highs are cleared at midnight, monthly highs are cleared at month-end midnight, yearly highs are cleared at year-end midnight. You may enter the month that you would like the yearly rainfall accumulation to clear. The yearly rainfall clears on the first day of the month you have chosen. The yearly high rain rate clears using the same setting.

The following table lists the high and low modes for all the weather variables:

Weather Variable	High	Low	Day, Time & Date	Month	Year	Additional Information
Wind Speed	Yes		Yes	Yes	Yes	Includes direction of highs
Outside Temperature	Yes	Yes	Yes	Yes	Yes	
Inside Temperature	Yes	Yes	Yes	Yes	Yes	
Outside Humidity	Yes	Yes	Yes	Yes	Yes	
Inside Humidity	Yes	Yes	Yes	Yes	Yes	
Barometer	Yes	Yes	Yes	Yes	Yes	
Heat Index	Yes		Yes	Yes	Yes	
Wind Chill		Yes	Yes	Yes	Yes	
Dew Point	Yes	Yes	Yes	Yes	Yes	
Rainfall Rate	Yes		Yes	Yes	Yes*	
Daily Rain			Total	Total	Total*	
Evapotranspiration			Total	Total	Total	Requires a Vantage Pro2 ISS with solar radiation sensor

* Stores yearly data for current and past years.

Weather data highs and lows

Viewing Highs and Lows

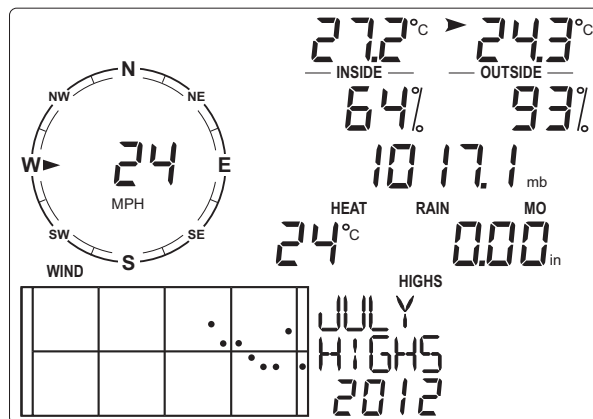

View of monthly highs

1. Press HI/LOW to enter the Highs and Lows Mode.



The day of the week and “DAILY HIGHS” display in the Weather Center section of the console and the console displays the highs for all visible fields.

2. Press the + and - keys to scroll through Day Highs, Day Lows, Month Highs, Month Lows, Year Highs and Year Lows.

The information provided in the Weather Center displays the day of the week, month or year being viewed as well as indicates if the screen currently being viewed is displaying highs or lows. The reading’s time and date, where applicable, appear in the time and date fields.

3. Press the < and > keys to scroll back and forth through the 26 values in the graph section of the console screen.

Pressing the < key displays the previous day’s highs. Each time you press the < key, the date moves back another day. The 26 dots in the graph field represent each of the current and last 25 days, months, or years. The right-most dot is the present. As you move backward and forward the flashing dot changes to show what value is being displayed.

4. Use the console navigation keys to select a different weather variable.

The console’s time displays the time of the selected variable’s high or low.

5. Press DONE to exit the Highs and Lows Mode. The console screen displays the Current Weather Mode.

Note: The low reading for wind chill and the high reading for heat index are displayed in the same place. When scrolling through the high and low screens with either of these variables selected, the wind chill and heat index readings toggle on and off depending on the screen displaying. If dew point is selected, neither wind chill nor heat index will be displayed.

Alarm Mode

The Vantage Vue features 22 alarms that can be programmed to sound whenever a reading exceeds or drops below a set value. With the exception of barometric pressure and time, all alarms sound when a reading reaches the alarm threshold. For example, if the high outside temperature alarm is set at 65° F/18°C, the alarm sounds when the temperature rises to or above 65.0° F/18.0°C. A barometric pressure alarm is triggered based on trend. A time alarm is based on a preset time.

Low alarms work the same way. For example, if the wind chill threshold is set for 30°F/-1°C, the alarm condition begins when the wind chill drops to 30°F/-1°C and will continue until the wind chill rises above 30°F/-1°C.

When an alarm condition exists, the audible alarm sounds, the alarm icon blinks repeatedly, and an alarm description appears in the Weather Center at the bottom of the screen. The alarm sounds for a maximum of two minutes (time alarm sounds for one minute) if the console is battery-powered, but the icon continues to blink and the message stays in the Weather Center until you clear the alarm or the condition clears. If you’re using the AC adapter, the alarm will continue sounding as long as the condition exists.



The alarm will sound again for each new alarm. If more than one alarm is active, the description for each active alarm along with a “+” symbol cycles onto the Weather Center section of the screen every four seconds.

Vantage Vue Alarms

Variable	Alarms
Barometric Pressure Trend	Storm Warning - uses trend value falling rate Storm Clearing - uses trend value rising rate
Evapotranspiration*	ET Alarm - uses total ET for the day
Humidity, Inside	High and Low
Humidity, Outside	High and Low
Dew Point	High and Low
Rain	Flash Flood Alarm - uses current 15 minute rainfall total 24 Hour Rain Alarm - uses current 24 hour rainfall total
Storm	Storm Alarm - uses current storm rainfall total
Rain Rate	High
Inside Temperature	High and Low
Outside Temperature	High and Low
Heat Index Temperature	High
Wind Chill Temperature	Low
Wind Speed	High and 10-Minute Average
Time & Date	The alarm sounds for 1 minute.

*Evapotranspiration measurements are only available when receiving data from Vantage Pro2 Plus stations or other Vantage Pro2 ISS stations in which a solar radiation sensor has been installed.

Special Alarms

ET (Evapotranspiration) (Optional)

Note: The ET Alarm is only available when the console is receiving data from a Vantage Pro2 Plus or Vantage Pro2 with solar radiation sensor. If your Vantage Vue console is not “listening to” a Vantage Pro2 Plus ISS, you cannot set an ET alarm.

ET is updated once an hour, on the hour. If during a given hour the ET value exceeds the alarm threshold, the ET alarm sounds at the end of that hour. This is true for daily, monthly, and yearly ET alarms. See “Evapotranspiration (ET)” on page 46 for a description of this variable.

Barometric Pressure

The Vantage Vue allows you to set two barometric pressure alarms: a “rise” alarm and a “fall” alarm. You may select any rate of change per three hours between 0.00 and 0.25 inches (6.35 mm) Hg, (8.5 mb, hPa). The alarm will sound if the rate of change (in either direction) exceeds the threshold you set. This alarm is updated every minute.

Setting Alarms

1. Press and release 2ND then press ALARM to enter the Alarm Mode to view or set the high alarm thresholds. The screen displays the current high alarm thresholds. The  icon displays and “HIGH ALARMS” displays in the Weather Center.



2. Press the < and > keys to select one of the variables displayed on the screen or use the console keys to select any weather variable. Also, press HI/LOW to display then toggle between the high and low alarm threshold settings.
3. Press 2ND then press SET to activate the currently selected weather variable.
4. Press the < and > keys to select digits in the threshold value.
5. Press the + and - keys to change the digit's value up and down.
6. Press DONE to finish changing the alarm setting.
7. Repeat steps 2 through 6 to change additional alarm settings.
8. Press DONE to exit Alarm Mode.



Setting the Time Alarm

1. Press and release 2ND then press ALARM to enter the Alarm Mode
The  icon displays and “HIGH ALARMS” displays in the Weather Center.
2. Press TIME, then press and release 2ND and press SET.
The hour digit in the time field begins blinking, displaying the current time.
3. Press the < and > keys to select between the hour digit and the minutes digits.
4. Press the + and - keys to change the digit's value up and down. To change between AM and PM, keep pressing + and - when the hour value is blinking.
5. Press DONE to exit Alarm Mode.

Clearing Alarm Settings

1. Press 2ND and ALARM to enter the Alarm Mode.
2. Select the alarm setting you wish to clear.
3. Press and release 2ND, then press and hold CLEAR until the setting changes to all dashes.
You have cleared the alarm setting.
4. Press DONE to exit Alarm Mode.

Silencing Alarms

1. Press DONE to silence (but not clear) an alarm when it sounds.

Changing Alarm Sound

1. Press and release 2ND then press ALARM to enter the Alarm Mode.
2. Press and release 2ND then press the + and - keys to change the sound of the alarm tone.

Note: This also changes the error sound.

3. Press DONE to exit Alarm Mode.

Graph Mode

The Vantage Vue console includes a powerful Graph Mode that allows you to view over 50 graphs of different weather data right on the screen, all without connecting to a personal computer.

The horizontal axis is time, showing the current and last 25 intervals (hours, days, months, or years). The vertical axis scale changes automatically to fit the information of the period graphed.

Viewing Graphs

Although the graphs available may vary for each weather variable, all are displayed in the same way.

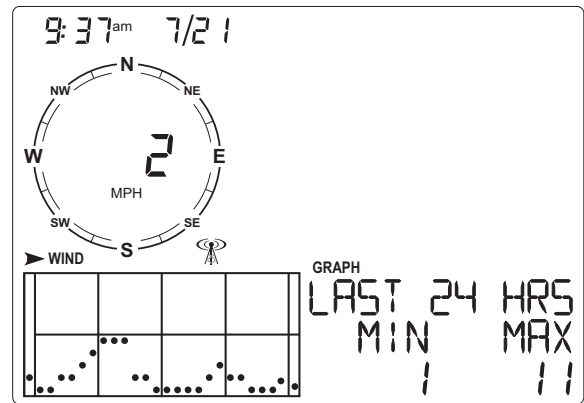

Graph Mode for the wind variable

1. Select a variable to graph.
2. Press GRAPH to enter Graph Mode. Only the time, date, graph, graph icon, selected variable and information pertaining to the selected variable are visible. The rest of the screen is blank.



Values for the present time and each of the preceding 25 hours are displayed in the graph, each hour represented by a dot. The dot at the right end of the graph is the value for the current hour. You'll notice that the dot is blinking. The dot at the left end of the graph is the value at least 24 hours ago.

3. Press the < key and the second dot from the right starts to blink.
The screen displays the new dot's value. The time display shows what hour is being viewed.
4. Press the < and > keys to view the variable's high values for each of the last 25 hours.
5. Press the + and - keys to shift the graph's time span.

If you press the - key, the graph shifts from the current and last 25 hours to the current and last 25 days. Each dot represents the high recorded on the day shown in the date field. To see the lows recorded in the current and last 25 days, press HI/LOW. Press the < and > keys to move between days.

By pressing the - key again, the graph shifts to show the highs of the current and last 25 months. As before, use the < and > keys to move between months. Press HI/LOW to shift between the highs and lows.

By pressing the - key again, the graph shifts one more time to show the highs of the current and last 25 years, but only for Rain Rate, Rain, and ET.

Since the console only graphs data collected by the station, graphs can only show data collected since the station was installed.

View graphs of all other variables the same way.

1. Select the variable you want to view.
2. Press GRAPH.
3. Use the < and > keys to select different values.
4. Press the + key to shorten the time range.
5. Press the - key to lengthen the time range.
6. Press HI/LOW to shift between highs and lows.
7. Press DONE to exit.

Vantage Vue Console Graphs

Weather Variable	Available Graphs			
	Hourly	Daily	Monthly	Yearly
Barometric Pressure	C	H, L	H, L	
Humidity, Inside	C	H, L	H, L	
Humidity, Outside	C	H, L	H, L	
Dew Point	C	H, L	H, L	
Rain	T	T	T	T
Rain Rate	H	H	H	H
ET (optional)	T	T	T	T
Inside Temperature	C	H, L	H, L	
Outside Temperature	C	H, L	H, L	
Heat Index Temperature	C	H	H	
Wind Chill Temperature	L	L	L	
Wind Speed*	A, H	H	H	
Direction of High Wind Speed		Y	Y	

Legend:

A = Average

H = Highs

L = Lows

T = Totals

Y = Yes

C = Current reading at the end of each period

* Also available: 10-Minute High Wind Speeds For Last 4 Hours; Current and last 25 Packets of Wind Speed.

Chapter 4

Troubleshooting and Maintenance

Vantage Vue Troubleshooting Guide

While your Vantage Vue weather station is designed to provide years of trouble-free operation, occasional problems may arise. If you are having a problem with your station, please consult this troubleshooting guide before calling Davis technical support. You may be able to quickly solve the problem yourself. Please see “Contacting Davis Technical Support” on page 52.

Note: Refer to the *ISS Installation Manual* for additional troubleshooting information.

TABLE 4-1: TROUBLESHOOTING GUIDE

	Problem	Solution
Display	Display is blank	Unit is not receiving power. Check the power adapter connections and/or replace batteries.
	Display shows dashes in place of weather data	<ul style="list-style-type: none">ISS is not transmitting. See ISS manual.Console not receiving - See “Troubleshooting Reception Problems” on page 37.A reading has exceeded the limits indicated in the specifications table. Calibration numbers may be causing readings to exceed display limits. Check calibration number and adjust if necessary.
	Console is sluggish or does not work at low temperatures	The console and display may not work below 32° F (0° C). Use an external temperature sensor in low-temperature locations or install the console indoors.
	Display “locks up”	Reset the console by removing AC and battery power then restoring power. If this occurs frequently in an AC-powered console, plug the AC power adapter into a surge suppressor, or use batteries. (They will last up to a year.)
	Console shows “Low Battery Stn X”	Replace the 3-volt lithium battery in the outdoor sensor suite. Refer to your Vantage Vue ISS manual. (The ISS’s transmitter ID number, rather than an X, will be shown.)
	Console shows “Low Console Batteries”	Replace the 3 C-cell batteries in the console.
Humidity	Inside humidity seems too high or too low	Make sure the console is not near a humidifier or dehumidifier. Check calibration number and adjust if necessary. If inside humidity is low, and inside temperature is too high, see temperature, below. Turn off the console backlight.



TABLE 4-1: TROUBLESHOOTING GUIDE

	Problem	Solution
Wind	Wind speed reading seems too low.	Remove wind cups and check for friction sources. Check the ISS location. Is it sheltered from the wind? See ISS manual for additional wind speed troubleshooting information.
	Wind speed reads 0 either all the time or intermittently	The problem may be with the wind cups. Test by spinning. Check the corresponding wind fields in the diagnostic screens and call technical support. (See “Screen 1: Statistical Diagnostic Screen” on page 39.)
	Wind reading is dashed out	Check reception. See Reception Problems below.
Dew	Dew Point reading seems too high or too low	Check calibration numbers for temperature. Dew point depends on outside temperature and humidity. Make sure both sensors are working.
Temperature	Outside temperature reading seems too high	Check calibration number and adjust if necessary. The ISS may need to be relocated away from radiant heat sources. See the <i>ISS Installation Manual</i> .
	Inside temperature sensor reading seems too high	Turn off console backlight. Move the console out of direct sunlight. Make sure the console or sensor is not in contact with an exterior wall that heats up in sunlight or when outside temperature rises. Make sure the console or sensor is not near a heater or other internal heat source (lamps, appliances, etc.). Check calibration number and adjust if necessary.
	Outside temperature seems too low	Check calibration number and adjust if necessary. Sprinklers may be hitting the ISS radiation shield. Relocate. See ISS manual.
	Inside temperature sensor reading seems too low	Make sure the console is not in contact with an exterior wall that cools down when outside temperature drops. Make sure the console is not near an air conditioning vent. Check calibration number and adjust if necessary.
Chill	Wind chill reading seems too high or too low	Check calibration numbers for temperature. Wind chill depends on temperature and wind speed. Make sure they’re working.
Heat	Heat Index reading seems too high or too low	Check calibration numbers for temperature. The heat index depends on temperature and outside humidity. Make sure the sensors are working.
Rain	No rain readings	Make sure the rain funnel is not clogged with debris. See the ISS manual.
Time	Incorrect times for sunrise and sunset	Check your latitude, longitude, time zone, and daylight saving time settings. Sunrise and sunset times are calculated from the console using all of these settings.

Troubleshooting Reception Problems

While we have tested the Vantage Vue radio extensively, each site and each installation presents its own issues and challenges. Obstructions, particularly metallic ones, can cut down your station’s reception distance. Be sure to test reception between the console and ISS in the locations you intend to install them before permanently mounting your ISS.

The console’s reception status displays as an antenna icon above the graph portion of the console screen.

- The antenna icon displays with waves flashing around it when the console is receiving data from the ISS. 
- The antenna icon displays alone when the console is trying to re-establish a lost connection. When no data packets have been received for 10 minutes, the console dashes-out any missing sensor readings. 
- The antenna icon disappears when the connection between the ISS and console is lost. The console tries for 10 minutes to re-establish a connection, then stops trying to connect with the ISS for 15 minutes, and then redisplay the antenna alone while it tries to re-establish a connection with the ISS. Enter and exit Setup Mode to re-display the antenna icon and manually force the console to re-establish a connection with the ISS.

Check Console Reception

Enter Setup Mode by pressing and releasing 2ND and pressing SETUP. Keep pressing DONE until the “Receiving From...”screen displays. (See “Screen 5: Active Transmitters” on page 8 for more information.) Wait a few minutes while the console lists all the stations transmitting within range. If the console does not detect your transmitter, check the following:

- Adjust the console antenna so that it is vertical and in line-of-sight the Vantage Vue ISS antenna.

Note: The Vantage Vue ISS antenna cannot be adjusted. Ensure that the console antenna is vertical.

- Check the ISS and transmitter ID numbers. See “Screen 6: Configuring Transmitter IDs” on page 9.
- Try reducing or increasing the distance between the ISS and the console. They should be at least 10 feet (3 meters) apart. Maximum range is 1000’ (300 m) line-of-sight.

Refer to the *ISS Installation Manual* for instructions on how to check the station for potential transmission problems.

Console Diagnostic Mode

In addition to logging weather data, the console continuously monitors the station’s radio reception. You may find this information very helpful, especially when you are choosing locations for your console and ISS.

The Console Diagnostics Mode consists of two screens: the Statistical Diagnostic Screen and the Reception Diagnostic Screen.

Note: Radio transmission data used by the diagnostic screens clears each day at midnight, except for % Good Packet graph data. Diagnostic screens are also cleared if you change your ID or go into the Setup Mode.

Diagnostic Screen Commands

- Press and hold TEMP, then press HUM to display the Statistical Diagnostic screen.
- Press 2ND and then press CHILL to toggle between the Statistical and Reception Diagnostic screens.
- Press DONE to exit the diagnostic screens.
- A degree (°) sign displays to the right of the last digit in Value 3 (in the area of the compass rose, see illustration on next page) of the Reception Diagnostic screen (screen 2) to differentiate which screen is currently displayed.

Screen 1: Statistical Diagnostic Screen

The Statistical Diagnostic Screen displays information about how well data is being received from the weather station to the console. The information that is displayed in this screen includes:

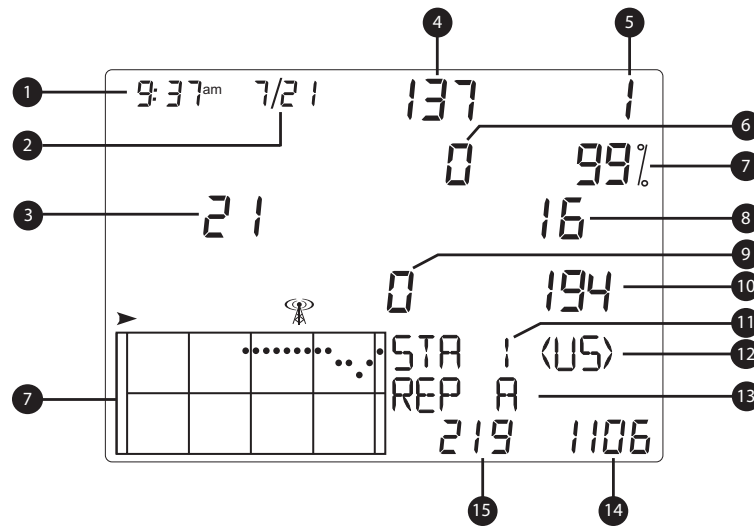

Note: Several of these values, with a *, are used by Davis engineers.

1. Time of day or number of times the anemometer switch was seen closed*. The reed switch closes once each revolution of the anemometer wind cups. Press WIND to toggle between these two values.
2. Date or the number of times the anemometer switch was seen open*. Press WIND to toggle between these two values.

Note: The time and date displays can be toggled in both statistical and reception diagnostic screens.

3. Number of packets containing “Cyclical Redundancy Check” (CRC) errors received. The system runs a CRC check on data packets. Any data packets that don’t pass this check are considered to contain errors and are discarded. These are considered bad packets. This also includes the CRC errors received during radio acquisition.
4. The firmware version currently installed on the console.
5. Maximum number of bad packets in a row without resynchronization.
6. Number of times the console resynchronized with the transmitter. The console will attempt to resynchronize with the station after 20 consecutive bad packets.
7. Percentage of good packets received. Graph shows the current and last 25 days of good packet percentage data. The vertical scale is fixed at 10% per dot.
8. The total number of bad data packets including missed packets and CRC errors. Missed packets are described as when a data packet is expected, but is not recognized as a data packet by the console. This does not include bad packets received during acquisition.
9. Current streak of consecutive bad packets. The counter increments when the console is synchronized but the packet is bad. This value is reset to zero when a good packet is received.
10. Current streak of consecutive good packets received.
11. Station Number
12. Transmitter Domain

13. Repeater ID currently communicating with the console. If a repeater or group of repeaters is used to relay station information to the console, the repeater ID displayed is the repeater that the console is set to receive. If the console is not “listening” to repeaters, this section remains blank.
14. Total number of good packets received.
15. Longest streak of consecutive good packets.

Screen 2: Reception Diagnostic Screen

The Reception Diagnostic screen displays information pertinent to the console’s wireless reception. To view this screen from the Statistical Diagnostic screen, press 2ND and then press CHILL. The degree sign displaying to the right of the last digit in Value 1 (see illustration below) verifies that the Reception Diagnostic screen is currently displayed.

The information that is displayed in this screen includes:

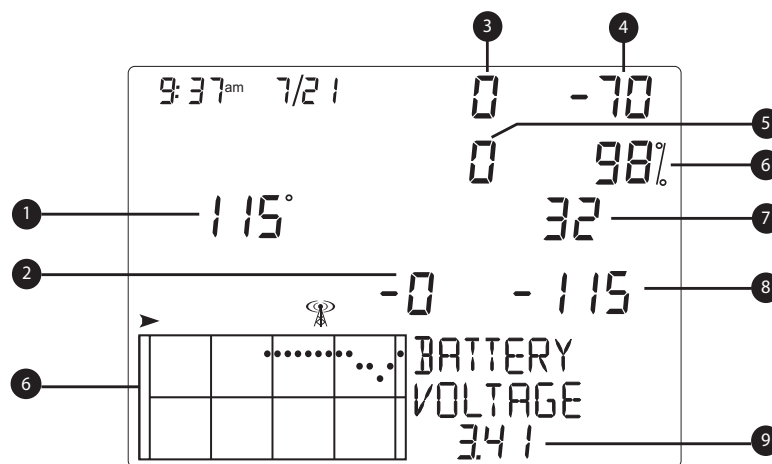

1. 8-bit timer value of next reception.*
2. Radio frequency error of the last packet received successfully. The ideal number should be zero after frequency correction is added. This value affects the value of #3.
3. Current frequency correction factor. Shows the frequency adjustment to the console.
4. Signal strength of the last packet received. The values displayed in this field show the received signal strength in dBm power. A more negative number means the signal strength is weaker while a less negative number means the signal strength is stronger. (Range: -100 to -20.) If a packet is not received successfully, the signal strength field is dashed out (--).
5. The number of times that the Phase Lock Loop did not lock.*
6. Percentage of good data packets. Graph shows the current and last 25 days of good packet percentage data. The vertical scale is fixed at 10% per dot.
7. Frequency index of the next packet to be received.*
8. Background noise level. This refers to the signal level that the console “hears” while it is not “listening” to a transmitter. Background noise is displayed as power level in dBm. The more negative the number is, the lower the background noise is. (Typically, this number should be about 15 lower than signal strength.)
9. Current console battery voltage. Ignore this value if using only an AC adapter to power the console.

Console Maintenance

Changing Batteries

If the message, LOW CONSOLE BATTERIES appears in the Weather Center, replace the batteries.

1. In order to avoid losing any stored weather data, plug in the AC adapter before removing the batteries.

Note: If you cannot plug in the AC adapter, enter Setup Mode by pressing and releasing 2ND and pressing SETUP. Entering Setup Mode makes sure the station isn't writing any data to memory when power is removed.

2. Remove the battery cover located on the back of the console by pressing down on the two latches at the top of the cover.
3. In the top battery compartment, insert a fingertip between the battery and the notched end of the compartment and remove the battery.
4. Repeat the process for the batteries in the bottom battery compartment.
5. Install the new batteries. (See "Installing Batteries" on page 3.)
6. Replace the battery cover and remove the AC power adapter, if desired.

Console Firmware Versions

From time to time Davis engineers update the Vantage Vue console firmware. View the firmware version in Value 4 in the Statistical Diagnostic screen, or by pressing and holding DONE and + from the Current Weather Mode screen.



You can check the firmware version currently available and download, at no charge, the newest firmware to your console on the Weather Software Support section of our website (<http://www.davisnet.com/support>). A WeatherLink data logger is required to update the firmware into the console.

One Year Limited Warranty

For details on our warranty policy, please refer to the *Maintenance, Service, and Repair Information* brochure included with your station.

Contacting Davis Technical Support

If you have any questions, or encounter problems installing or operating your Vantage Vue weather station, please contact Davis Technical Support. We're glad to help. **(510) 732-7814** — Monday - Friday, 7:00 a.m. - 5:30 p.m. Pacific Time. We are unable to accept collect calls.

(510) 670-0589 — Technical Support Fax.

support@davisnet.com — E-mail to Technical Support.

info@davisnet.com — General e-mail.

www.davisnet.com — Davis Instruments website.

See the Weather Support section for copies of user manuals, product specifications, application notes, and information on software updates. Watch for FAQs and other updates.

Appendix A

Weather Data

















Refer to this appendix to learn more about the weather variables that are measured, displayed, and logged by your Vantage Vue station. The following variables are arranged below in the order they are viewed on the console screen: left to right, top to bottom, starting with time.

Time

A built-in clock and calendar track the time and date. The console automatically adjusts for daylight saving time and leap year in most of North America, and Europe (and allows manual adjustment elsewhere). The console also displays the sunrise and sunset times based on the latitude and longitude, time and date, and your time zone/UTC offset.









Moon Phases

The moon phase icons and moon phase description in the Weather Center section of console screen are calculated based on latitude and longitude, time and date and your time zone/UTC Offset. The following table displays the moon phase icons and description for the Northern and Southern Hemispheres.

Icon: Northern Hemisphere	Moon Phase Description in the Weather Center	Icon: Southern Hemisphere
	NEW MOON	
	WAXING CRESCENT MOON	
	FIRST QUARTER MOON	
	WAXING GIBBOUS MOON	
	FULL MOON	
	WANING GIBBOUS MOON	
	LAST QUARTER MOON	
	WANING CRESCENT MOON	

Forecast

The forecast icons show what weather conditions may occur within the next 12 hours. The console generates a weather forecast based on the barometric reading and trend; wind speed and direction; rainfall; temperature; humidity; latitude and longitude; and time of year. The forecast is updated once an hour, on the hour and requires three hours of data. Predictions are made for cloud cover and the likelihood of precipitation.

Forecast Icon	Description of Forecasted Weather
	Mostly clear
	Partly cloudy
	Mostly cloudy
	Rain likely
	Snow likely
	Rain possible but not likely
	Snow possible but not likely
	Rain, freezing rain, sleet and/or snow likely
	Rain, freezing rain, sleet and/or snow possible but not likely

Wind

The anemometer measures wind speed and direction, and is part of the Integrated Sensor Suite (ISS). The console calculates a 2-minute average wind speed, a 10-minute average wind speed and 10-minute dominant wind direction. The 2- and 10-minute average wind speed are displayed in the Weather Center whenever wind has been selected on the console. The last six 10-minute dominant wind directions are included in the compass rose wind display.

Beaufort Scale

The Beaufort Scale is an empirical measure for describing wind speed which ranks wind speeds in classes. The Beaufort Scale classification for the current wind condition is listed in the Weather Center when WIND is pressed and WxCEN is pressed several times. See “Wind Speed and Direction” on page 17 for more information.

Wind Speed	Beaufort Number	Description
0 -1 mph; (0 -1.6 kph)	0	Calm
1-3 mph; (1.6 - 4.8 kph)	1	Light Air
3 - 7 mph; (4.8 - 11.3 kph)	2	Light Breeze
7 -12 mph; (11.3 - 19.3 kph)	3	Gentle Breeze
12 - 18 mph; (19.3 - 29.0 kph)	4	Moderate Breeze
18 - 24 mph; (29.0 - 38.6 kph)	5	Fresh Breeze
24 - 31 mph; (38.6 - 49.9 kph)	6	Strong Breeze
31 - 38 mph; (49.9 - 61.2 kph)	7	Near Gale
38 - 46 mph; (61.2 -74.1 kph)	8	Gale
46 - 54 mph; (74.1 - 86.9 kph)	9	Strong Gale
55 - 63 mph; (88.5 - 101.4 kph)	10	Storm
64 - 73 mph; (103.0 - 117.5 kph)	11	Violent Storm
74 mph or above; (119.1 kph)	12	Hurricane

Temperature

The ISS houses the outside temperature sensor in a vented and shielded enclosure that minimizes solar radiation-induced temperature error. The console houses the inside temperature sensor.

Humidity

Humidity itself simply refers to the amount of water vapor in the air. However, the total amount of water vapor that the air can contain varies with air temperature and pressure. Relative humidity takes into account these factors and offers a humidity reading which reflects the amount of water vapor in the air as a percentage of the amount the air is capable of holding. Relative humidity, therefore, is not actually a measure of the amount of water vapor in the air, but a ratio of the air’s water vapor content to its capacity. When we use the term humidity in the manual and on the screen, we mean relative humidity.

It is important to realize that relative humidity changes with temperature, pressure, and water vapor content. If a parcel of air with a capacity for 10 g of water vapor contains 4 g of water vapor, the relative humidity would be 40%. Adding 2 g more water vapor (for a total of 6 g) would change the humidity to 60%. If that same parcel of air is then warmed so that it has a capacity for 20 g of water vapor, the relative humidity drops to 30% even though water vapor content does not change.

Relative humidity is an important factor in determining the amount of evaporation from plants and wet surfaces since warm air with low humidity has a large capacity to absorb extra water vapor.

Wind Chill

Wind chill takes into account how the speed of the wind affects our perception of the air temperature. Our bodies warm the surrounding air molecules by transferring heat from the skin. If there is no air movement, this insulating layer of warm air molecules stays next to the body and offers some protection from cooler air molecules. However, wind sweeps away that warm air surrounding the body. The faster the wind blows, the faster heat is carried away and the colder you feel. Wind has a warming effect at higher temperatures.

Note: There is no windchill when the air temperature is at or above 93° F (-34° C).

Heat Index

Heat index uses temperature and the relative humidity to determine how hot the air actually “feels.” When humidity is low, the apparent temperature will be lower than the air temperature, since perspiration evaporates rapidly to cool the body. However, when humidity is high (*i.e.*, the air is more saturated with water vapor) the apparent temperature “feels” higher than the actual air temperature, because perspiration evaporates more slowly.

Note: Heat index and air temperature are equal at or below 0° F (-18° C).

Dew Point

Dew point is the temperature to which air must be cooled for saturation (100% relative humidity) to occur, providing there is no change in water vapor content. The dew point is an important measurement used to predict the formation of dew, frost, and fog. If dew point and temperature are close together in the late afternoon when the air begins to turn colder, fog is likely during the night. Dew point is also a good indicator of the air’s actual water vapor content, unlike relative humidity, which takes the air’s temperature into account. High dew point indicates high water vapor content; low dew point indicates low water vapor content. In addition a high dew point indicates a better chance of rain, severe thunderstorms, and tornados.

You can also use dew point to predict the minimum overnight temperature. Provided no new fronts are expected overnight and the afternoon relative humidity is greater than 50%, the afternoon’s dew point gives you an idea of what minimum temperature to expect overnight. The higher the humidity is, the more accurate the dew point prediction.

Note: Dew point is equal to the air temperature when the humidity is 100%.

Rain

Vantage Vue incorporates a tipping spoon rain collector in the ISS that measures 0.01" or 0.2 mm for each tip of the spoon. Your station logs rain data in the same units it is measured in and converts the logged totals into the selected display units (inches or millimeters) at the time it is displayed. Converting at display time reduces possible compounded rounding errors over time.

Four separate variables track rain totals: “rain rate,” “daily rain,” “monthly rain,” and “yearly rain.” Rain rate calculations are based on the interval of time between each spoon tip, which is each 0.01" or 0.2 mm rainfall increment.

Barometric Pressure

The weight of the air that makes up our atmosphere exerts a pressure on the surface of the earth known as atmospheric pressure. Generally, the more air above an area, the higher the atmospheric pressure. This means that atmospheric pressure changes with altitude. For example, atmospheric pressure is greater at sea level than on a mountaintop. To compensate for this difference and facilitate comparison between locations with different altitudes, atmospheric pressure is adjusted to the equivalent sea level pressure. This adjusted pressure is known as barometric pressure. In reality, Vantage Vue measures atmospheric pressure. When you enter your location's altitude in Setup Mode, Vantage Vue stores the necessary offset value to consistently translate atmospheric pressure into barometric pressure.

Barometric pressure also changes with local weather conditions, making barometric pressure an extremely important and useful weather forecasting tool. High pressure zones are generally associated with fair weather while low pressure zones are generally associated with stormy weather. For forecasting purposes, however, the value of the absolute barometric pressure is generally less important than the change in barometric pressure. In general, rising pressure indicates improving weather conditions while falling pressure indicates deteriorating weather conditions.

Evapotranspiration (ET)

Evapotranspiration (ET) is a measurement of the amount of water vapor returned to the air in a given area. It combines the amount of water vapor returned through evaporation (from wet surfaces) with the amount of water vapor returned through transpiration (exhaling of moisture through plant stomata) to arrive at a total. Effectively, ET is the opposite of rainfall, and it is expressed in the same units of measure (inches, millimeters).

Vantage Vue uses air temperature, relative humidity, barometric pressure, average wind speed, and solar radiation data to estimate ET, which is calculated once an hour on the hour. Measuring ET requires that the Vantage Vue console "listen" to an optional Vantage Pro2 Plus station with a solar radiation sensor installed.

Solar Radiation

What we call "current solar radiation" is technically known as Global Solar Radiation, a measure of the intensity of the sun's radiation reaching a horizontal surface. This irradiance includes both the direct component from the sun and the reflected component from the rest of the sky. The solar radiation reading gives a measure of the amount of solar radiation hitting the solar radiation sensor at any given time, expressed in Watts/sq. meter (W/m^2). Measuring solar radiation requires that the Vantage Vue console "listen" to an optional Vantage Pro2 Plus station with a solar radiation sensor installed. Solar Radiation is displayed in the Weather Center when ET is pressed and WxCEN is pressed multiple times.

UV (Ultra Violet) Radiation

Energy from the sun reaches the earth as visible, infrared, and ultraviolet (UV) rays. Exposure to UV rays can cause numerous health problems, such as sunburn, skin cancer, skin aging, cataracts, and immune system suppression. Measuring UV radiation requires that the Vantage Vue console "listen" to an optional Vantage Pro2 Plus station with a UV radiation sensor installed. The UV Index is displayed in the Weather Center when ET is pressed and WxCEN is pressed multiple times.

Appendix B

Specifications

See complete specifications for your Vantage Vue Station at our website: www.davisnet.com.

Console Specifications

Console Operating Temperature	+32° to +140°F (0° to +60°C)
Non-Operating (Storage) Temperature	+14° to +158°F (-10° to +70°C)
Console Current Draw	0.9 mA average, 30 mA peak, (add 120 mA for display lamps, add 0.125 mA for each transmitter station received by console) at 4.4 VDC
Power Adapter	5 VDC, 200 mA
Battery Backup	3 C-cells
Battery Life (no AC power)	Up to 9 months (approximately)
Housing Material	UV-resistant ABS plastic
Console Display Type	LCD Transflective
Display Backlight	LEDs
Dimensions:	
Console (with antenna) on table	7.5" x 5.75" x 4.5" (190 mm x 146 mm x 114 mm)
Console (with antenna) mounted on wall	7.5" x 7.0" x 3.0" (190 mm x 178 mm x 76 mm)
Display	4.13" x 3.0" (105 mm x 76 mm)
Weight (with batteries)	1.48 lbs. (.67 kg)

Wireless Communication Specifications

Transmit/Receive Frequency	US Models: 902 - 928 MHz Overseas Models: 868.0 - 868.6 MHz
ID Codes Available.	8
Output Power	902 - 928 MHz FHSS: FCC-certified low power, less than 8 mW, no license required 868.0 -868.6 MHz: CE-compliant, less than 8 mW, no license required
Range	
Line of Sight	up to 1000 feet (305 m)
Through Walls	200 to 400 feet (60 to 120 m)

Console Data Display Specifications

Historical Data	Includes the past 25 values plus the current value unless otherwise noted; all can be cleared and all totals reset.
Daily Data	Includes the earliest time of occurrence of highs and lows; period begins/ends at 12:00 AM
Monthly Data	Period begins/ends at 12:00 AM on the first of every month.
Yearly Data	Period begins/ends at 12:00 AM on January 1 st unless otherwise noted.
Current Data	Current data appears in the right-most column in the console graph and represents the latest value within the last period of the graph; totals can be set or reset.
Graph Time Interval	10 min., 1 hour, 1 day, 1 month, 1 year (user-selectable, availability depends upon variable selected) (2.5 seconds for Last 24 Wind Speeds)
Graph Time Span	26 Intervals (Current interval plus 25 past values included; see Graph Intervals to determine time span.)
Graph Variable Span (Vertical Scale)	Automatic (varies depending upon data range); maximum and minimum value in range appear in Weather Center.
Alarm Indication	Alarms sound for 2 minutes (except for time) if operating on battery power. Alarm message displays in Weather Center as long as threshold is met or exceeded. Alarms can be silenced, but not cleared, by pressing DONE.
Transmission Interval	Varies with transmitter ID code from 2.25 seconds (#1=shortest) to 3 seconds (#8=longest)
Update Interval	Varies with sensors. See "Update Interval by Sensor" on page 50.
Forecast:	
Variables Used	Barometric reading & trend, wind speed & direction, rainfall, temperature, humidity, latitude & longitude, time of year.
Update Interval	1 hour
Display Format	Icons on top center of display; displays weather conditions that may occur for the next 12 hours.
Variables Predicted	Sky condition, precipitation

Weather Data Specifications

Note: The following weather data specifications are listed as they are displayed on the console.

Weather Data Specifications

Variable	Resolution	Range	Nominal Accuracy (+/-)
Wind Direction	1°	0 to 360°	3°
Compass Rose	22.5°	16 compass pts.	
Wind Speed	1 mph; 1 kt; 0.5 m/s; 1 km/h	2 to 180 mph; 2 to 156 kts 3 to 290 km/h, 1 to 80 m/s	Greater of 2 mph/kts; 1 m/s; 3 km/h or 5%
Inside Temperature	0.1°F; 0.1°C	+32° to +140°F; 0 to +60°C	1°F; 0.5°C
Outside Temperature *	0.1°F; 0.1°C	-40° to +150°F; -40° to +65°C	1°F; 0.5°C
Inside Humidity	1%	1 to 100%	3% RH; 4% above 90%
Outside Humidity	1%	1 to 100%	3% RH; 4% above 90%
Barometric Pressure**	0.01" Hg; 0.1 mm Hg; 0.1 hPa; 0.1 mb	16" to 32.5" Hg; 410 to 820 mm Hg; 540 to 1100 hPa; 540 to 1100 mb	0.03" Hg; 0.8 mm Hg 1.0 hPa; 1.0 mb
Barometric Trend (3 hour)	Change Rates Rapidly: ≥.06" Hg; 1.5 mm Hg; 2 hPa; 2 mb Slowly: ≥.02" Hg; 0.5 mm Hg; 0.7 hPa; 0.7 mb	5 Arrow Positions: Rising Rapidly Rising Slowly Steady Falling Slowly Falling Rapidly	
Dew Point	1°F; 1°C	-105° to +130°F; -76° to +54°C	3°F; 1.5°C
Heat Index	1°F; 1°C	-40° to +165°F; -40° to +74° C	3°F (1.5°C)
Wind Chill	1°F; 1°C	-110° to +135°F -79° to +57°C	2°F; 1°C

* Outside temperature accuracy is based on the temperature sensor itself and not on the sensor and the passive shielding together. The solar radiation induced error for the radiation shield: +4°F (2°C) at solar noon with the wind speed at less than or equal to 2 mph (1 m/s); The higher the wind speed, the less solar radiation induced error.

** Barometric pressure readings are standardized to sea level. Elevation Range: -999' to +15,000'; -600 to +4660 m. Note: The console screen limits entry of lower elevation to -999' when using feet as elevation unit. For elevations below -999', use meters.

Weather Data Specifications

Variable	Resolution	Range	Nominal Accuracy (+/-)
Rainfall	0.01"; 0.2 mm (1mm at totals over 2000 mm)	to 199.99"; 6553 mm	Greater of 4% or 1 tip
Rain Rate	0.01"; 0.1 mm	to 40"/hr.; 1016 mm/hr.	5% when rate is under 5"/hr.; 127 mm/hr.
Evapotranspiration (ET)*	0.01"; 0.1 mm	Daily to 32.67"; 999.9 mm Monthly & Yearly to 199.99"; 1999.9mm	greater of 5% or 0.01"; 0.25 mm
Solar Radiation*	1 W/m ²	0 to 1800 W/m ²	5% of full scale
UV Index**	0.1 Index	0 to 16	5% of full scale
Time	1 min	24 hours	8 sec/Mon.
Date	1 day	month/day	8 sec/Mon.

* Console must be receiving from a Vantage Pro2 Plus or Vantage Pro2 with solar radiation sensor installed.

**Console must be receiving from a Vantage Pro2 Plus or Vantage Pro2 with UV radiation sensor installed.

Update Interval by Sensor		
BAR	Barometric Pressure	1 min.
HUMIDITY	Inside Humidity	1 min.
	Outside Humidity	50 sec.
	Dew Point	10 sec.
RAIN	Rainfall Amount	20 sec.
	Rain Storm Amount	20 sec.
	Rain Rate	20 sec.
TEMPERATURE	Inside Temperature	1 min.
	Outside Temperature	10 sec.
	Heat Index	10 sec.
	Wind Chill	10 sec.
WIND	Wind Speed	2.5 sec.
	Wind Direction	2.5 sec.
	Direction of High Speed	2.5 sec.

Appendix C

Wireless Repeater Configuration

Vantage Pro2 Wireless Repeaters (#7626, #7627) or Long-Range Wireless Repeaters (#7653, #7654) can be added to increase transmission distances or improve transmission quality between a station and a console. A repeater receives information transmitted from a Vantage Vue or Vantage Pro2 station and retransmits it to a console. Depending on transmission distance, one repeater or several repeaters can be used to collect and retransmit weather data. All consoles communicating with repeaters must be set up with the correct Transmitter ID and Repeater ID before the console can correctly receive station information.

Setting Repeater ID

To set a repeater ID on the console:

1. Press 2ND and SETUP to enter Setup Mode.
2. Press DONE repeatedly to display Screen 6: Configuring Transmitter IDs.
See “Screen 6: Configuring Transmitter IDs” on page 9 for more information on configuring Transmitter IDs.
3. Press 2ND and then WIND to turn the repeater function on and to select a repeater ID.
Pressing 2ND and WIND sets the console to receive the signal from a repeater instead of directly from a station. The first Repeater ID displayed is repeater A.
4. Press WIND repeatedly to cycle through all eight repeater IDs or to clear the repeater ID in the right-hand corner. When no repeater ID is shown, the console is configured to “listen” directly to a station and not to a repeater.

In this example, the console is set up to receive from an ISS station on transmitter ID 1 from repeater A.



5. Continue pressing DONE to move through the other screens in the Setup Mode, or press and hold DONE to return to the Current Weather Mode.

Clearing Repeater ID

If a repeater ID is being displayed in Screen 6 and you are not using a repeater, you must turn off the repeater function to receive station information successfully.

In Setup Screen 6:

Press 2ND and then press WIND repeatedly so that the console cycles through the list of repeater IDs (Repeaters A-H) until the section where the repeater ID was displayed is blank. Press DONE to continue to the next screen or press and hold DONE to return to the Current Weather Mode.

Vantage Vue Console Icons

Console icons indicate weather conditions and special functions.

Forecast

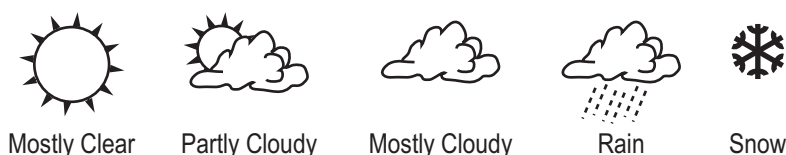

Forecast icons show what weather conditions may occur for the next 12 hours.

Moon Phase

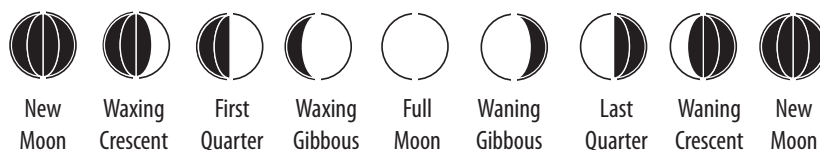

Shows the current moon phase. Sequence shown for Northern Hemisphere. The sequence of the icons is reversed in the Southern Hemisphere.

Alarm Bell

Flashes when an alarm is triggered. Indicates when the console is in Alarm Mode.



Graph

Appears next to the currently selected weather variable. Indicates the graphed variable on most screens.



Second Function

Appears when you press 2ND. Indicates that console key secondary functions are enabled.



Rain

Appears when the ISS is currently detecting rain.



Barometric Pressure Trend

Arrows show direction of pressure change for last three hours.



Contacting Davis Technical Support

If you have any questions or encounter problems installing or operating your Vantage Vue weather station, contact Davis Technical Support. We're glad to help.

(510) 732-7814 — Monday - Friday, 7:00 a.m. - 5:30 p.m. Pacific Time. We are unable to accept collect calls.

(510) 670-0589 — Technical Support Fax.

support@davisnet.com — E-mail to Technical Support.

info@davisnet.com — General e-mail.

www.davisnet.com — Davis Instruments web site.

See the Weather Support section of our website for copies of user manuals, product specifications, application notes, and information on software updates. Watch for FAQs and other updates.