

# Wireless Leaf & Soil Moisture/Temperature Station

## Installation Manual

---

### For Wireless Vantage Pro2™ and Vantage Pro2 Plus™

The Wireless Leaf & Soil Moisture/Temperature Station (referred to in this document as the Leaf/Soil Station) can be used with any Wireless Vantage Pro2 weather station to measure leaf wetness, soil moisture, or temperature.

The following Vantage Pro2 console station configurations can be used with the Leaf/Soil Station:

<b>Station Type in Console Configuration</b>	<b>Number of Leaf Wetness Sensors</b>	<b>Number of Soil Moisture Sensors</b>	<b>Number of Temp Probes</b>
LEAF/SOIL Station	2	4	4
LEAF Station	2	-	2
SOIL Station	-	4	4

- Only one Leaf/Soil Station can be installed as a Leaf/Soil Station per Vantage Pro2 Weather Station.
- Two stations can be installed if one is configured as a Leaf Station and the other station is configured as a Soil Station in the Vantage Pro2 console.
- Configured as a Leaf Station, the Station supports two leaf wetness sensors and two temperature probes.
- Configured as a Soil Station, it supports up to four soil moisture sensors and temperature probes.

---

Note: In any station using soil moisture sensors, the corresponding temperature probe, if installed, will be used for temperature compensation of the soil moisture sensor.

---

### Tools for Setup

In addition to the components shown, you will need some or all of the following materials:

- Adjustable wrench or 7/16" wrench
- Medium Phillips Screwdriver
- Ballpoint pen or paper clip (small pointed object of some kind)
- Drill and 3/16" (5 mm) drill bit (if mounting on a vertical surface)
- Stepped Sensor Installation Tool for Soil Moisture and Temperature Sensors (recommended, see page 16)

## Components

The Leaf/Soil Station includes the following components and hardware:

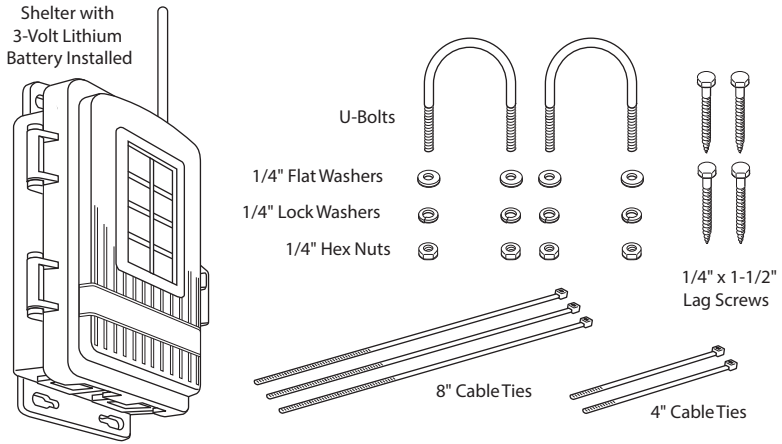

## Optional Sensors

The following optional sensors are available for the Leaf/Soil Station:

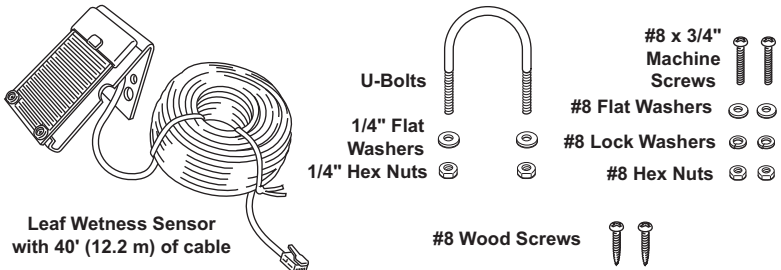

Optional Leaf Wetness Sensor (#6420)

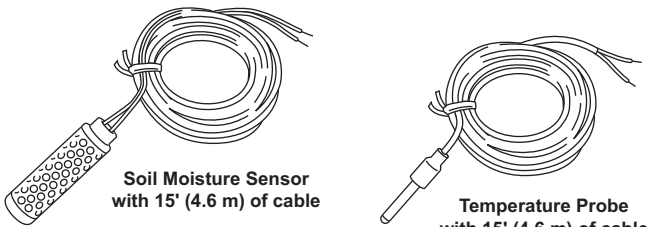

Optional Soil Moisture Sensor (#6440) and Optional Temperature Sensor (#6470)

---

## Installation Steps

For ease of installation and use of your Leaf/Soil Station, please follow steps in the order presented.

- Preparing the station, page 3
- Setting the transmitter ID, page 5
- Choosing a location to mount the station, page 8
- Mounting the station, page 9
- Rules for using the sensors, page 10
- Installing leaf wetness sensors, page 11
- Installing soil moisture and temperature sensors, page 13
- Using soil moisture readings, page 17

If you encounter difficulties or have questions about your station, the following additional information may be helpful:

- Troubleshooting the sensors, page 18
- Extending Sensor Cables, page 18
- Contacting Davis Technical Support, page 19
- Specifications, page 19
- FCC Warning, page 20

## Preparing the Leaf/Soil Station

The following illustrations show the location of the transmitter ID DIP switches, the battery mounting location, the modular connectors used by the leaf wetness sensors, and the terminal blocks used to connect the soil moisture sensors and temperature probes.

## Remove the Battery Pull Tab

1. Remove the pull tab from the installed 3-volt lithium battery. Make sure the battery is firmly seated in the compartment.
2. Note the location of the DIP switches. You will work with them during the next installation step.

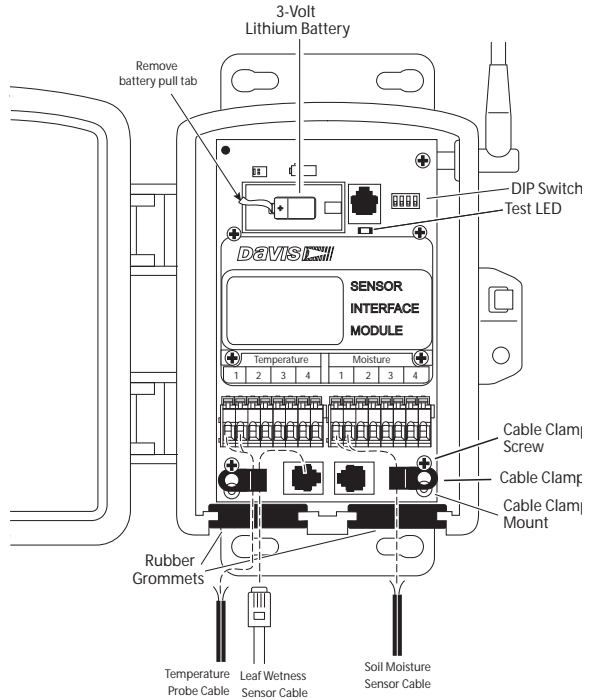

## Temporarily Connecting a Sensor for Testing

Temporarily connect at least one of the following sensors.

Note: You must have at least one sensor installed in the Leaf/Soil station in order to test wireless communications.

### Leaf Wetness Sensor Connection

- Connect the leaf wetness sensor cable to the LEAF 1 or LEAF 2 receptacle by plugging it in the proper receptacle.

### Soil Moisture Sensor Connection

Temporarily connect a soil moisture probe to the SOIL 1 terminal block connector using the following instructions.

1. Use a pen or small screwdriver to open the connector “jaws” as shown in the illustration at the top of the next page.
2. While the jaws are open, insert the temperature probe leads, then let the connector jaws close in on the lead by removing the pen or small screwdriver.

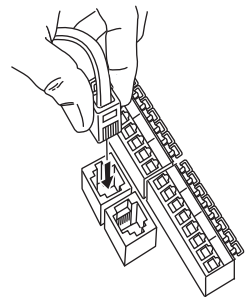

Connecting a Leaf Wetness Sensor

Note: The soil moisture sensor must be moist to be used for this test. A completely dry sensor will not register on the console.

---

## Soil Temperature Sensor Connection

Temporarily connect a temperature probe to the TEMP 1 terminal block connector.

1. Use a pen or small screwdriver to open the connector “jaws” as shown in the illustration to the right.
2. While the jaws are open, insert the temperature probe leads, then let the connector jaws close in on the lead by removing the pen or small screwdriver.

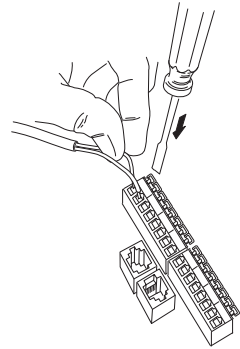

*Connecting a Soil Moisture or Temperature Sensor*

## Setting the Transmitter ID

Each wireless transmitting station must be set to one of eight transmitter IDs. DIP switches #1, 2 and 3 on the Sensor Interface Module (SIM) allow you to control the ID — the “channel” the station will transmit on. (DIP switch #4 is used for transmission testing, not for transmitter ID.)

---

Note: A transmitter and receiver communicate with each other only when both are set to the same ID.

---

The factory default transmitter ID is ‘1’. Looking at the table below, you can see that means the DIP switches are in the OFF position when each transmitting station leaves the factory. This is true for all Davis wireless equipment.

1. Verify the transmitter ID used by your ISS, as well as all other transmitter IDs already used by your Vantage Pro2 Weather Station.
2. Configure the Leaf/Soil Station to a transmitter ID not already in use.
3. Use a ballpoint pen or paper clip to toggle DIP switches #1, 2, and 3. The settings for transmitter IDs 1 – 8 are shown in the table below:

ID Code	Switch 1	Switch 2	Switch 3
#1 (default)	OFF	OFF	OFF
#2	OFF	OFF	ON
#3	OFF	ON	OFF
#4	OFF	ON	ON
#5	ON	OFF	OFF
#6	ON	OFF	ON
#7	ON	ON	OFF
#8	ON	ON	ON

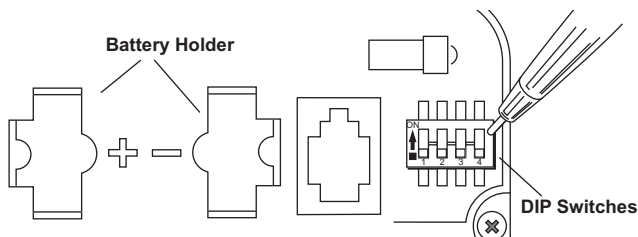

*Transmitter DIP Switches in Top-right Corner of SIM*

## Setting Console/Receiver(s) to Same ID

1. Put your console into Setup Mode — press and hold DONE and press the down arrow (-).
  - The console displays the words: “RECEIVING FROM...” and “STATION NO.” followed by the transmitter IDs that your console detects. One of these should be the ID number you just set on the Leaf/Soil Station transmitter. It can take up to two minutes to show all transmitter IDs received.
  - If you don’t see the station on the console screen, make sure the console is within 10’ of the transmitter, and verify that you set the DIP switches correctly. Wait a few seconds and if you still don’t see it, go to “Troubleshooting Communication Problems” on the next page.
2. Press DONE to move to “Screen 2: Selecting Transmitters.”
  - Setup Mode – Screen 2 is where you will set the console to recognize signals on that ID as coming from a Leaf/Soil Station.
3. Press the left (<) or right (>) arrows to scroll through transmitter IDs.
  - When you see the ID you chose for the Leaf/Soil Station, press the up (+) or down (-) arrows to activate reception of that ID code. Make sure the screen shows “ON (ISS)”.
4. Press GRAPH several times to change the station type in the console from ON (ISS) to ON (LEAF), ON (SOIL), or ON (LEAF/SOIL).
  - Configure it as a LEAF Station if you are only using it for leaf wetness and temperature.
  - Configure it as a SOIL station if you are only using it for soil moisture and temperature.
  - Configure it as a LEAF/SOIL station if you are using it for both leaf wetness and soil moisture.
5. To exit Setup Mode, press and hold DONE.

---

Note: See the Vantage Pro2 User’s Manual & Setup Guide: “Setup Mode – Screen 2: Selecting Transmitters” for more information.

---

---

## Testing Station Communications

1. If you are using a Soil Moisture sensor to test the station, press TEMP until you see “SOIL MOIST” displayed on the console screen where the inside temperature is usually displayed. If you are using a Leaf Wetness sensor, press HUM until you see “LEAF WET” displayed where you usually see the inside humidity. Both TEMP and HUM will display temperatures if you are using a temperature probe to test the station.
  - Soil temperature is displayed in the TEMP OUT location on the LCD. Leaf temperature is displayed below the barometer reading on the LCD.
  - If you see SOIL MOIST or LEAF WET and no number, you are seeing the moisture and temperature readings for sensor pair #1. A two, three or four will appear above the readings for the second, third or fourth set of sensors.
2. If you continue to press TEMP or HUM, you will see the readings for sensor pairs #2, #3 and #4 (#3 and #4 are displayed for soil moisture and temperature only).
  - If no sensor is installed, the reading for that sensor will be dashed out.
3. A soil moisture, temperature, or leaf wetness reading confirms communication between your Leaf/Soil Station and the console.
  - Disconnect the sensor(s) that were temporarily installed to test communications.
  - Go on to “Choosing a Location to Mount the Station” on page 8.

If your console does not show a sensor reading, proceed to “Troubleshooting Communication Problems.”

## Troubleshooting Communication Problems

First, verify that the console/receiver is powered and is not in Setup Mode (exit Setup Mode by pressing DONE and holding it for a moment). Then, on the Leaf/Soil Station, check that the battery is properly installed. Walk around the room with the console, standing for a few moments in various locations to see if you are picking up signals.

If you don't see any readings, no matter where you stand with the console, put the transmitter in TEST mode as described below.

### TEST mode

DIP switch #4 on the SIM (see illustration on page 6) is the TEST DIP switch. Switch it to the ON position using a ball-point pen or paper clip. This puts the transmitter in *Test Mode*. The test LED will flash each time the transmitter broadcasts a signal, which should be about every 2.5 seconds.

If the LED flashes only once and then remains dark, or does not flash at all, there is a problem with the transmitter. See “Contacting Davis Technical Support” on page 19.

---

If the LED flashes repeatedly but your console isn't picking up a signal anywhere in the room, it could be related to one of the following causes:

- The DIP switches were not correctly set on the transmitter. Review the procedure on page 5.
- The ID was not correctly set on the console/receiver. Review the procedure on page 6.
- Reception is being disrupted by RF (radio frequency) interference.
- There is a problem with the console/receiver. See "Contacting Davis Technical Support" on page 19.

---

Note: Remember to turn DIP switch #4 OFF when you're finished testing wireless transmission. If it is left ON, the blinking LED will reduce battery life significantly.

---

## Choosing a Location to Mount the Station

Try to position your Leaf/Soil Station as follows:

- With the solar panel positioned for maximum exposure to the sun.
- Within transmission range of your Vantage Pro2 console. See "Range of Wireless Transmission" on page 8.
- Within cable range of the sensors:
  - Leaf Wetness Sensors come with 40' (12 m) of cable standard and can be extended up to 200' (61m) using 6-conductor 26 AWG cable.
  - Soil Moisture Sensors come with 15' (4.6 m) of cable standard and can be extended up to 1000' (300m) using #18 gauge UF cable.
  - Temperature Sensors come with 15' (4.6 m) of cable standard and can be extended up to 800' (242m) using #24 AWG shielded cable or up to 1200' (260m) using #22 AWG shielded cable.

## Range of Wireless Transmission

The range of wireless transmission depends on many factors. For the best reception, position the transmitter shelter and your console/receiver as close together as possible.

The maximum range is up to 1,000' (300 m) in the line of sight, under optimal conditions. Typical range under most conditions is 200' to 400' (75 to 150 m), but this may be reduced by walls, ceilings, trees, or foliage. Radio-frequency interference (RF) can also reduce transmission distance. Cordless phones and baby monitors are common examples of devices that can cause RF interference.

A metal roof or other large metal structure can interfere with the signal. Aluminum siding, a furnace with metal ducts, and your refrigerator are examples. Sometimes transmission between wireless units is obscured by something you cannot identify, or by some obstacle that you can't work around. If necessary, consider using Wireless Repeater #7626 or #7627 to strengthen the signal or increase the distance between the transmitter and the console/receiver.



---

## Testing Transmission from Proposed Location

It is very important to test reception from the proposed location before permanently mounting the Leaf/Soil Station.

- Place the shelter at the intended mounting site, or have someone hold it there, so you can walk around with the console/receiver for a few minutes. Rotating the antenna so that the transmitting and receiving antennas are parallel to each other may help to improve reception.
- Test wireless reception anywhere you might want to use or mount your console and receiver now or in the future. Take your time. If you aren't picking up strong signals where you intend to place your console, move the shelter before it is mounted.
- If you have irregular terrain in the area, it may interfere with the signal. For example, if the transmitter is mounted downhill from the console/receiver, the ground may block a wide angle of the transmitted signal.

## Mounting the Leaf/Soil Station

### Mounting on a Vertical Surface

1. With a 3/16" (5 mm) drill bit, drill two holes approximately 2" (50 mm) apart. Use a carpenter's level to ensure the holes will be level.
2. Drill two more holes 7-1/32" below the upper holes.
3. Insert the 1/4" x 1-1/2" lag screws through the flat washers, and through the holes at the top and bottom of the shelter into the post.
4. Using an adjustable wrench or 7/16" wrench, tighten the lag screws.

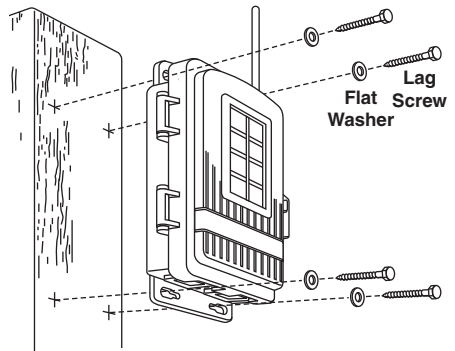

### Mounting on a Pole

1. While holding the shelter against the pole, place a U-bolt around the pole and through the two holes on at the top of the shelter.

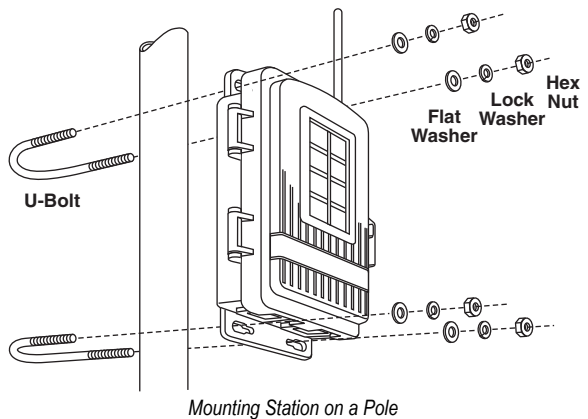

2. Place a flat washer, a lock washer and a hex nut on each of the bolt ends.
3. Using an adjustable wrench or 7/16" wrench, tighten the nuts.
4. Place the second U-bolt around the pole and through the two holes at the bottom of the shelter.
5. Put a flat washer, a lock washer, and a hex nut on each bolt end, and tighten the hex nuts.

Note: If no soil temperature probe is used, the console will use a default temperature of 75°F (24°C) to compensate the soil moisture sensor readings.

6. To prevent fraying or cutting of cables, secure them so they will not whip about in the wind. Secure a cable to a metal pole by wrapping electrical tape around them both. Make sure cables are secure by placing clips or ties approximately every 3 – 5' (1 – 1.6 m).

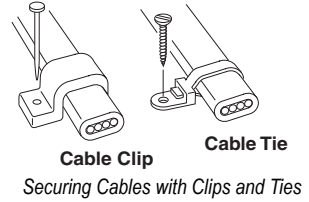

Note: Do not use metal staples or a staple gun to secure cables. Metal staples — especially when installed with a staple gun — have a tendency to cut the cables.

## Rules for Using Leaf, Soil and Temperature Sensors

The following station and sensor configurations are supported by the Leaf/Soil Station:

Station Type in Console Configuration	Number of Leaf Wetness Sensors	Number of Soil Moisture Sensors	Number of Temperature Probes
LEAF/SOIL Station	2	4	4
LEAF Station	2	-	2
SOIL Station	-	4	4

- A station configured as a LEAF station in the console will support two leaf wetness sensors and two leaf temperature probes.
- Leaf temperature probes can be used as you wish to measure air, water, or soil temperature. Leaf temperature does not affect leaf wetness readings.
- A station configured as a SOIL station in the console will support four soil moisture sensors and four soil temperature probes.
- If you have installed any soil moisture sensors (SOIL 1, SOIL 2, SOIL 3, SOIL 4), the corresponding temperature probes (TEMP 1 for SOIL 1, etc.) will be used to provide temperature compensation for the soil moisture sensor readings.
- If you want to use a temperature sensor for something besides compensation for a soil moisture sensor, then you cannot use the corresponding soil moisture sensor.

- To use one soil temperature sensor to provide compensation for multiple soil moisture sensors, install the temperature sensor in TEMP 1.
- If the station is configured as a combined LEAF/SOIL station, the value displayed for Leaf Temperature #1 will be same value displayed for Soil Temperature #1. The same is true for Leaf and Soil Temperature #2.
- If no soil temperature sensors are installed, the station will use the default temperature of 75°F (24°C) to compensate the soil moisture readings. The soil moisture accuracy will be off by about 1% for each 1°F (0.5°C) difference between the actual soil temperature and 75°F (24°C).

## Installing Leaf Wetness Sensors

The leaf wetness sensor enables the station to detect the presence of surface moisture on foliage and calculate the duration of wetness. When moisture is present, the sensor detects an electrical resistance change between the gold-plated elements of the grid. This is displayed by the Vantage Pro2 console as a value between 0 (dry) and 15 (wet). Using the WeatherLink® software with the Agricultural/Turf Management Module, you may select your own wetness threshold; the software will then calculate leaf-wet hours.

See the next section, “Installing Soil Moisture & Temperature Sensors” on page 13 for information on installing temperature sensors.

## Connecting Leaf Wetness Sensors

1. Run the sensor cables up through the grommets on the bottom of the station housing.
2. Insert the sensor cable modular plug into the Leaf 1 or Leaf 2 modular connector.

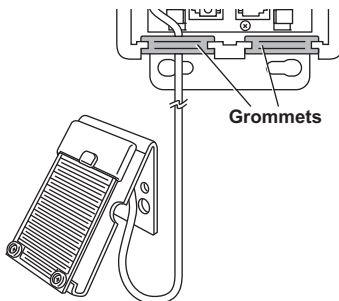

*Leaf Wetness Sensor Cables Run Through Grommets*

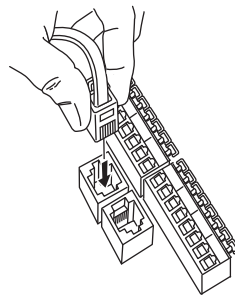

*Connecting Leaf Wetness Sensors*

---

## Finishing the Sensor Connections to the Station

1. Secure sensor cables within the cable clamps located next to the grommets.
2. Secure the cable clamps using the by screwing them to the cable clamp mounts inside the housing near the grommets.

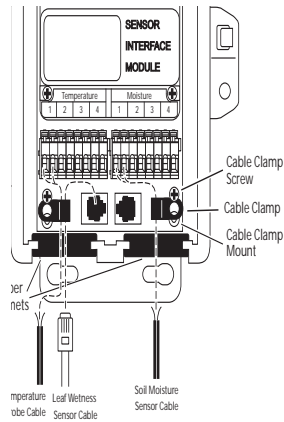

*Securing Sensor Cables*

3. To prevent fraying or cutting of cables, secure them so they will not whip about in the wind. Secure a cable to a metal pole by wrapping electrical tape around them both. Make sure cables are secure by placing clips or ties approximately every 3 – 5' (1 – 1.6 m).

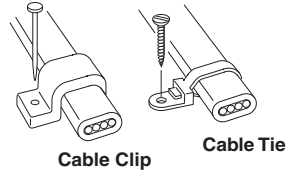

*Securing Cables with Clips and Ties*

---

**Note:** Do not use metal staples or a staple gun to secure cables. Metal staples — especially when installed with a staple gun — have a tendency to cut the cables.

---

## Mounting the Sensor Against a Wooden Surface

To mount the sensor against a wooden surface, secure the sensor to the surface using the #8 wood screws as shown below.

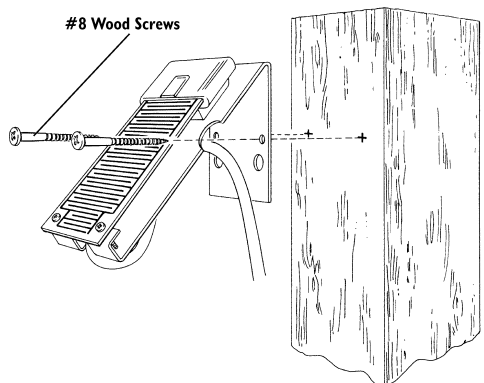

*Mounting on a Wooden Surface*

---

## Mounting the Sensor on a Pipe

To mount the sensor on a pipe, stake, or pole with outside diameter between 1" and 1-1/4" (25 mm and 31 mm), secure the sensor to the pipe using the 1-1/2" U-bolts, 1/4" flat washers, and 1/4" hex nuts as shown below. Use a 7/16" wrench or adjustable wrench to tighten the hex nuts.

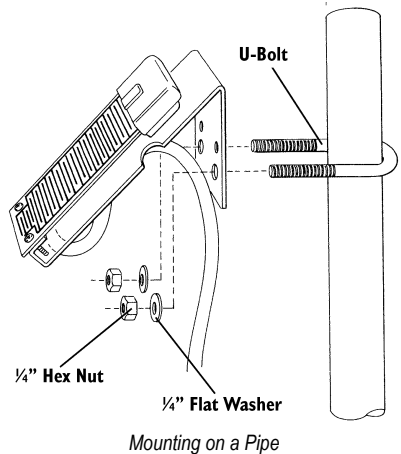

## Installing Soil Moisture & Temperature Sensors

The soil acts as a reservoir to store water between irrigation or rainfall events, so that it is available to the crop or plants as needed for healthy growth. The purpose of using sensors to measure the soil water is to give you a better understanding of how fast water is being depleted in the different areas of your field or lawn, so you can better schedule your irrigations and correctly evaluate the true effectiveness of any rainfall. By monitoring the soil moisture between irrigations, you will gain a more accurate picture of this process over time, and develop an irrigation scheduling pattern to meet your crop's "need" for water. This minimizes the guesswork, resulting in water savings, lower pumping costs, and the elimination of excess leaching of nitrogen due to over irrigation.

While not absolutely necessary for operation, we recommend that a temperature probe be installed with each soil moisture sensor. This allows the soil moisture sensor's readings to be temperature compensated for better accuracy.

---

Note: WATERMARK Soil Moisture Sensor information based on material supplied by Irrrometer Company, Inc.

---

## Connecting Soil Moisture and Temperature Sensors

1. Run the sensor cables up through the grommets on the bottom of the station housing.
2. Connect the temperature probes to the TEMP connectors.
3. Connect soil moisture probes to the SOIL connectors

Each matched temperature probe and soil moisture pair must use the matching connectors. If a temperature probe is not used, the soil moisture reading can be off as much as 1% for every 1°F (0.5°C) difference between the actual soil temperature and the default value. If no soil temperature probe is used for a particular soil moisture sensor, the soil temperature #1 value is used if present. Otherwise, the

---

console will use a default temperature of 75° F (24° C) to compensate the soil moisture readings.

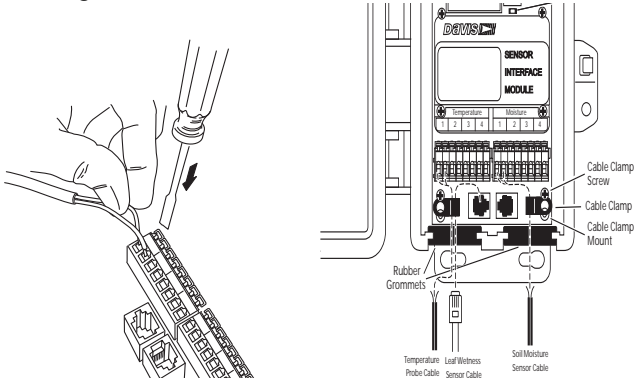

*Running Soil Moisture and Temperature Sensor*

*Connecting Soil Moisture and Temperature Sensors*

### Finishing the Sensor Connections to the Station

1. Secure sensor cables within the cable clamps located next to the grommets. See the above illustration.
2. Secure the cable clamps using the by screwing them to the cable clamp mounts inside the housing near the grommets.
3. To prevent fraying or cutting of cables, secure them so they will not whip about in the wind. Secure a cable to a metal pole by wrapping electrical tape around them both. Make sure cables are secure by placing clips or ties approximately every 3 – 5' (1 – 1.6 m).

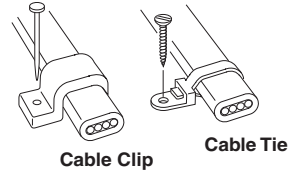

*Securing Cables with Clips and Ties*

---

Note: Do not use metal staples or a staple gun to secure cables. Metal staples — especially when installed with a staple gun — have a tendency to cut the cables.

---

### Locating Sensors

Be aware of the soil variations in your field or lawn. The lighter soils dry very quickly, heavier soils more slowly. Both conditions must be considered.

### Furrow or Flood Irrigation

- Sensors are usually placed about 2/3 of the way down the run, just ahead of the tail or backup water. This is the area where water penetration is usually the poorest.
- In tree crops, place the sensors on the drier side of the tree exposed to the most sun. In the Northern Hemisphere, this is typically the Southwest side of the tree, which is exposed to the hot afternoon sun.

---

## Sprinkler Irrigation

- Sprinkler irrigation usually provides a more uniform distribution of water to the ground surface, but there can be great differences in penetration and holding capacity due to soil type variations, soil interfaces and contour. Try to place your sensors in the areas where variations occur.
- In tree crops, locate sensors at the drip line.
- In row crops, locate sensors right in the plant row.
- Be sure that sensors are not located behind obstructions, such as tree limbs, which would interfere with water distribution to the sensor area.
- With center pivots, place sensors at 3 locations down the length of the pivot, just in front of the "start" point.
- Place sensors at "hot spots" or "good production" areas being sure to stay in active root zones.

## Drip or Micro Irrigation

- Place sensors in the wetted area. With drip emitters, this is usually 12” to 18” from the emitter.
- With micro-sprinklers or sprays, usually 24” to 36” from the micro-sprinkler is best.

## Sensor Depths

Sensor depth depends on the rooting depth of your crop, and also depends on soil depth and texture.

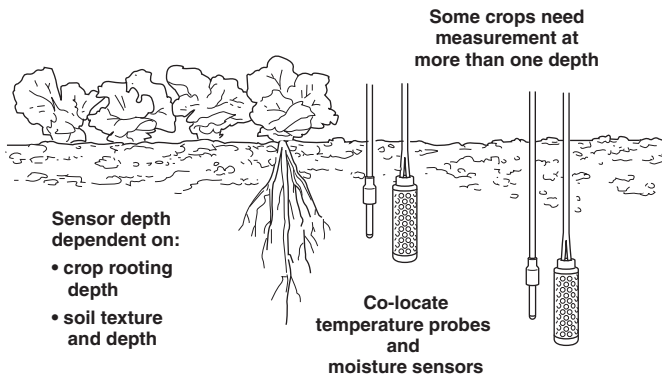

*Sensors must be located in the effective root system of the crop*

- With shallow rooted (less than 12”) vegetable crops, one depth may be adequate.
- Deeper rooted row crops, small grains, vines, and trees need to be measured in at least two depths.
- With deep well-drained soils, crops generally root deeper if moisture is available.
- With coarse, shallow or layered soils, root systems may be limited in depth.

- Guidelines on proper depths for specific crops and conditions can be obtained from your local farm advisor. Irrrometer also maintains an excellent resource listing the suggested placement for soil moisture sensors by crop at [www.irrometer.com](http://www.irrometer.com).

## Installation Procedure

1. Soak the soil moisture sensors overnight in water.
  - Always “plant” a wet soil moisture sensor.
  - If time permits, wet the soil moisture sensor for 30 minutes in the morning and let dry until evening, wet for 30 minutes and let dry overnight, wet again for 30 minutes the next morning and let dry again until evening. Soak over the next night and install wet. This will improve sensor response during the first few irrigations or waterings.
2. Make sensor access holes to the depth required with a 7/8” diameter rod.
  - Make a hole for the soil moisture sensor and a separate adjacent hole for the temperature probe.
  - For very coarse or gravelly soils, an oversize hole of 1” to 1 1/4” may be needed to prevent abrasion damage to the soil moisture sensor membrane. In this case, you will need to “grout in” the sensor with a slurry made from the sample soil to get a snug fit in the soil.
3. Always install sensors in the active root system of the crop with a snug fit in the soil.

---

Note: In gravelly soils and with deeper sensors, carefully install the sensor to prevent damaging the membrane.

---

- Lack of a snug fit is the biggest problem in obtaining good soil moisture sensor readings.
  - The ideal way of making the access hole is to use a stepped installation tool. The stepped tool makes an oversize hole for the upper portion and an exact sized hole at the bottom where the sensor is located.
  - The illustration to the right shows the dimensions required to make a stepped installation tool.
4. After installing the soil moisture sensor the hole needs to be carefully backfilled and tamped down. This prevents the creation of air pockets which could allow water to channel down to the sensor.
  - Fill the hole with water and push the sensor down into the hole so it bottoms out.
  - A length of 1/2” Class 315 PVC tubing fits snugly over the sensor collar and can be used to push the sensor. A good snug fit in the soil is important.

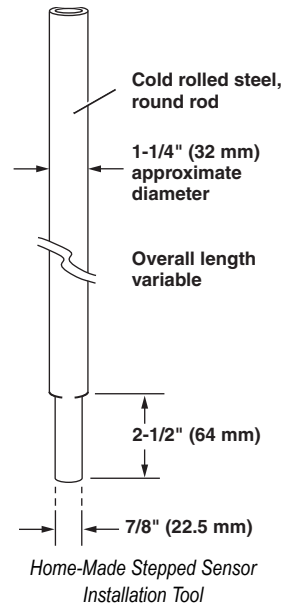



- Carefully backfill the access hole with soil to eliminate any air pockets.
5. You can solvent weld the 1/2" Class 315 PVC tubing to the sensor collar for easier installation and removal.
  - Use a PVC/ABS cement (IPS Weld-on #794 or equivalent).
  6. After you have installed the soil moisture sensors, the sensors will need one or two irrigation cycles to "break-in" and acclimate to the soil conditions and provide better accuracy.

### Installation Procedure for Turf/Lawns

1. Cut a slight "V" shaped trench about 5" wide at the top and about 6" deep into the turf--about 6" long.
2. Lift out the turf plug piece you just cut.
3. Press the sensors into the soil at about a 45 degree angle into the side of the trench to set the sensors about 3"-5" below the soil surface. Make sure they are good and snug in the soil.
4. Set the plug removed from the trench and compact it back into place. It will repair itself in short order.
5. Run the wires to the Leaf/Soil Station and connect them as described in "Connecting Soil Moisture and Temperature Sensors" on page 13.
6. If you withhold irrigation for several days and allow the soil to dry down a bit, you should see the soil moisture readings start to creep upward.
7. Usually, you will not need to water the turf until the reading is in the 25-40 area at the recommended 3"-5" depth.

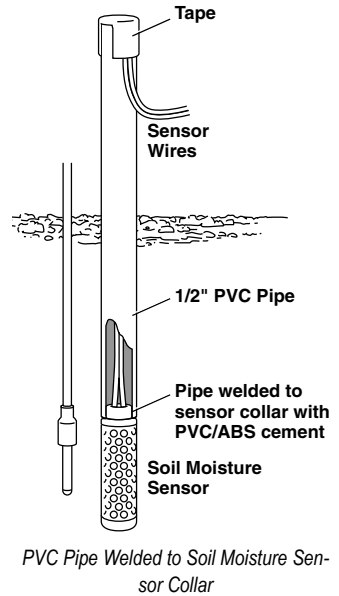

### Removing the Sensors

1. When removing sensors prior to harvest in annual crops, it's a good idea to do this just after the last irrigation when the soil is moist.
2. Do not pull the sensor out by the wires. You may have to dig out, at least partially, any sensors more than 12" deep or any sensors in dry soil. Careful removal prevents sensor and sensor membrane damage.
3. When sensors are removed for winter storage, clean the sensors, dry them, and place them in a clean, dry location.

### Using Soil Moisture Readings

Use this table as a general guide to interpret soil moisture readings. Monitoring the soil moisture readings, and comparing them to your field or lawn conditions over time, will help you develop a better understanding of how to interpret your soil moisture readings.

Centibar Reading	Soil Condition
0-10	Saturated Soil. Occurs for a day or two after irrigation.
10-20	Soil is adequately wet (except coarse sands which are drying out at this range)
30-60	Usual range to irrigate or water (except heavy clay soils). Irrigate at the upper end of this range in cool humid climates and with higher water-holding capacity soils.
60-100	Usual range to irrigate heavy clay soils
100-200	Soil is becoming dangerously dry for maximum production. Proceed with caution.

### Troubleshooting the Sensors

If you are having problems with your station, please check all sensor cable connections. Cable connections account for a large portion of potential problems.

Use these tests to verify the correct operation of your soil moisture sensor:

1. With the sensor submerged in water, the station should show a reading between 0 and 5.
2. Let the sensor air dry for 30 to 48 hours. Depending on ambient temperature, humidity, and air movement, the reading should be 150 or over.
3. Put the sensor back in the water. The reading should run right back to 0 to 5 within 1 to 2 minutes.
4. If the sensor does not pass these tests, please contact Davis Technical Support for help in resolving the problem.

### Extending Sensor Cable Length

Both the soil moisture sensors and the temperature probes come with 15' (4.6 m) direct burial cables. The leaf wetness sensor comes with a 40' (12m) cable.

- Leaf Wetness Sensor cables can be extended up to 200' (61m) using 6-conductor 26 AWG cable.
- Soil Moisture Sensor cables can be extended up to 1000' (300m) using #18 gauge waterproof cable. UF insulation is recommended.
- Temperature Sensors can be extended up to 800' (242m) using #24 AWG shielded cable or up to 1200' (260m) using #22 AWG shielded cable.
- The additional wire must be fully waterproof.
- We recommend using a 3M Scotchpak or Duraseal heat shrink splice connector when extending the sensor cables.

---

Note: Avoid long wire runs near power cables. The transient currents can affect the small current used to read the sensors.

---

---

# Contacting Technical Support

For questions about the Wireless Leaf & Soil Moisture/Temperature Station please contact Davis Technical Support. We'll be glad to help.

---

Note: Please do not return items to the factory for repair before calling to get a Return Materials Authorization number.

---

<b>Online</b>	<b>www.davisinstruments.com</b> Find copies of user manuals, product specifications, application notes, software updates, and more.
<b>E-Mail</b>	<b>support@davisinstruments.com</b>
<b>Telephone</b>	<b>(510) 732-7814</b> Monday - Friday, 7:00 A.M.- 5:30 P.M., Pacific Time

## Specifications

### General

Operating Temperature . . . . .	-40° to +150°F (-40° to +65°C)
Non-operating Temperature . . . . .	-50° to +158°F (-45° to +70°C)
Current Draw . . . . .	0.14 mA (average), 30 mA (peak) at 4 to 6 VDC power
Battery . . . . .	CR123A 3-Volt Lithium cell
Battery Life . . . . .	8 months without sunlight - greater than 2 years depending on solar charging
Solar Panel . . . . .	0.5 Watts
Housing Material . . . . .	UV-resistant PVC plastic
Dimensions . . . . .	6.25" x 2.25" x 7.875" (158.75 mm x 57.15 mm x 200 mm)
Weight . . . . .	1.08 lb. (.49 kg) (with battery, without sensors)

### Leaf Wetness Sensor (6420)

Sensor Type . . . . .	Electrical resistance
Cable Type . . . . .	4-conductor, 26 AWG
Connector . . . . .	Modular connector (RJ-11)
Maximum Cable Length . . . . .	200' (61 m) using 4-conductor 26 AWG cable

### Watermark Soil Moisture Sensor (6440)

Sensor Type . . . . .	Electrical resistance
Standard Cable . . . . .	15' (4.6 m) Watermark standard two-wire, stripped and tinned
Maximum Cable Length . . . . .	800' (243 m) (18 AWG UF wire recommended)

## Multi-Purpose Temperature Probe (6470)

Sensor Type	Thermistor
Standard Cable	15' (4.6m) 22 AWG direct burial cable, stripped and tinned
Maximum Cable Length	24 AWG: 800' (242 m), 22 AWG: 1200' (365 m)

## Wireless Communications

ID Codes Available	8
Range	
Line of Sight	up to 1000 feet (300 m)
Through Walls	200 to 400 feet (75 to 150 m)

REGION	FREQUENCY RANGE & POWER OUTPUT
USA	902 - 928 MHz FHSS, <8mW
EU	868.0 - 868.6 MHz FHSS, <8mW
Australia, Brazil	918 - 926 MHz FHSS, <8mW
New Zealand, Peru	921 - 928 MHz FHSS, <8mW
India	865 - 867 MHz FHSS, <8mW
Japan	928.15 - 929.65 MHz FHSS, <1mW
Taiwan	920 - 925 MHz FHSS, <8mW

## FCC Part 15 Class B Registration Warning

This equipment has been tested and found to comply with the limits for a class B digital device, pursuant to Part 15 of the FCC Rules. These limits are designed to provide reasonable protection against harmful interference in a residential installation. This equipment generates, uses and can radiate radio frequency energy and, if not installed and used in accordance with the instructions, may cause harmful interference to radio communications. However, there is no guarantee that interference will not occur in a particular installation.

If this equipment does cause harmful interference to radio or television reception, which can be determined by turning the equipment off and on, the user is encouraged to try to correct the interference by one or more of the following measures:

Reorient or relocate the receiving antenna.

Increase the separation between the equipment and receiver.

Connect the equipment into an outlet on a circuit different from that to which the receiver is connected.

Consult the dealer or an experienced radio/TV technician for help.

Changes or modifications not expressly approved in writing by Davis Instruments may void the user's authority to operate this equipment.

This product (model 6345OV) complies with the essential protection requirements of the Radio Equipment Directive 2014/53/EU. The complete Declaration of Conformity is one our website at <https://www.davisnet.com/legal>. RoHS Compliant.

Wireless Leaf & Soil Moisture/Temperature Station Manual

Product Numbers: 6345, 6345OV

Document Number 7395.267 Rev. D 10/28/19

Copyright © 2019 Davis Instruments Corp. All rights reserved. Vantage Pro®, Vantage Pro2™ and

Vantage Pro2 Plus™ are trademarks of Davis Instruments Corporation, Hayward, CA.

Davis Instruments Quality Management System is ISO 9001 certified. Information in this document is subject to change without notice.



3465 Diablo Avenue, Hayward, CA 94545-2778 U.S.A.  
510-732-9229 • Fax: 510-732-9188  
[info@davisinstruments.com](mailto:info@davisinstruments.com) • [www.davisinstruments.com](http://www.davisinstruments.com)